









L'acier, l'aluminium. Travailler et exploiter toutes leurs possibilités pour concevoir du mobilier au design innovant, en répondant toujours à une vraie fonctionnalité, tel est notre leitmotiv. Avec , l'acier prend forme, se transforme, devient matière à idées... pour vous étonner, vous amuser, vous séduire. Innover pour rendre la vie plus belle, plus simple. Jouer des formes et des couleurs. Avoir matière à se faire plaisir... Nos créations s'intègrent dedans, dehors, et vous permettent de composer selon vos besoins, avec les différentes combinaisons possibles de formats, de coloris et de finitions.  libère vos envies en inventant un mobilier qui vous ressemble, d'une qualité irréprochable, résistant aux intempéries et facile à monter.

L'usine.  mise avant tout sur la qualité des produits et la maîtrise des process de fabrication. Elle dispose de sa propre unité de production près de Lyon. Le design est confié depuis la création de la marque à des designers de renom ou en devenir.

Notre crédo. Apporter joie de vivre, couleurs, gaîté dans vos aménagements et combiner notre créativité à notre savoir-faire pour vous proposer des produits originaux, exclusifs, durables, nouveaux !



Steel, aluminium. To explore and utilise all means possible in the design of innovative furniture, where form follows function, that is our motto. With , steel takes shape, transforms, and becomes the physical expression of our ideas... to surprise you, delight you, and seduce you. Innovation makes the world more beautiful and yet more simple. The interplay of shape and colour.  creations are not just furniture, but works of art. Our designs are crafted for both interior and outdoor environments, with a range of specialist materials available according to your needs and requests, in a variety of size, colour and finish combinations.  frees your desires by inventing furniture that reflects your personality, is of the highest quality, is weather resistant and is easy to assemble.

The Workshop. 's highest priority is product quality, through strict control of the manufacturing process. Our production facility is located just outside of Lyon, France. All of our designs have been created exclusively for  by a variety of renowned artists and emerging talents.



Our Philosophy. We bring the joys of life, colour, and style into your world, combining our creativity and expertise to offer you original, exclusive, durable, inventive, and innovative products to inspire you for years to come.

made
in France

Nos produits sont fabriqués en :

-  **Acier** Usage intérieur uniquement.
-  **Aluminium** Usage intérieur et extérieur. Obligatoire pour le bord de mer.
-  **Acier galvanisé** Usage intérieur et extérieur. Ne convient pas pour le bord de mer.

Our products are manufactured in:

-  **Steel** Only for indoor use.
-  **Aluminium** For indoor & outdoor use. Strictly recommended for outdoor use, especially for the seaside.
-  **Galvanized steel** For indoor & outdoor use. Not suitable for the seaside.

Toutes les dimensions
données dans le catalogue
sont en cm.
All dimensions given
in the catalog are in cm.

L. Longueur Length
P. Profondeur Depth
H. Hauteur Height

Les Exceptionnelles | *The Amazing ones*

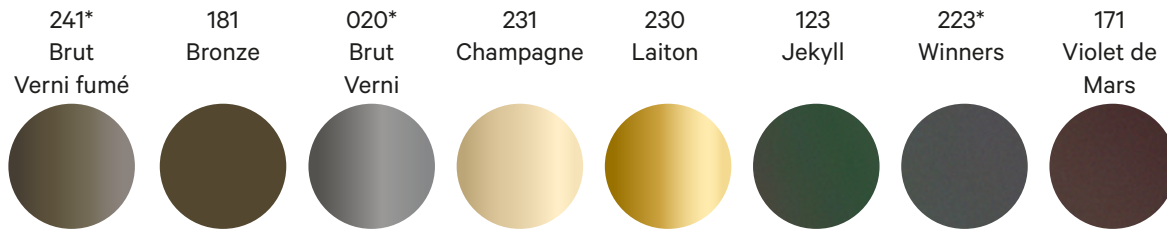

Les Tendances | *The Fashion ones*

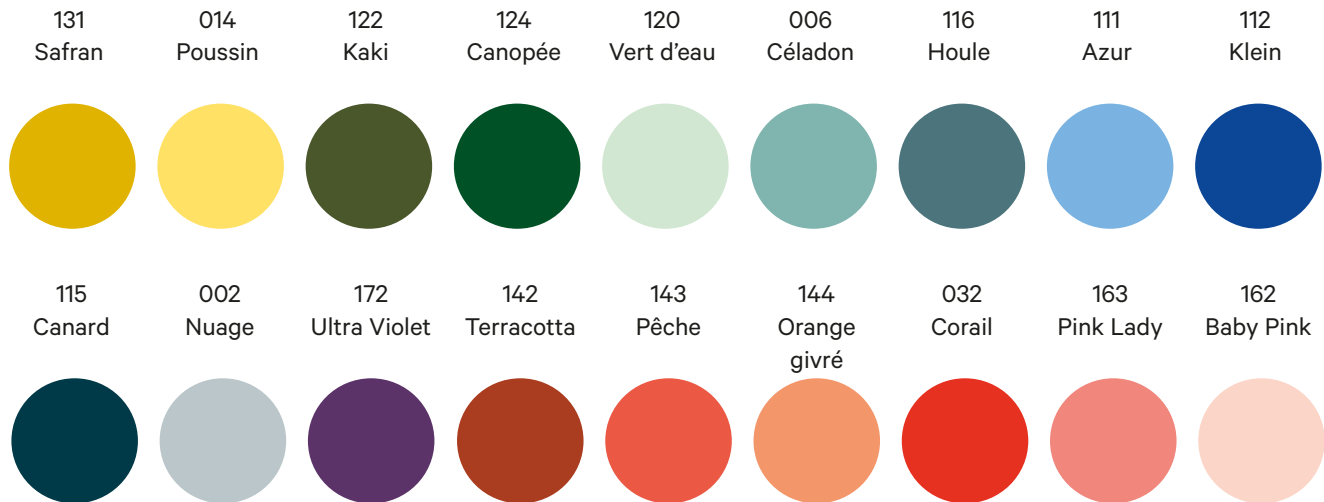

Les Intemporelles | *The Timeless ones*

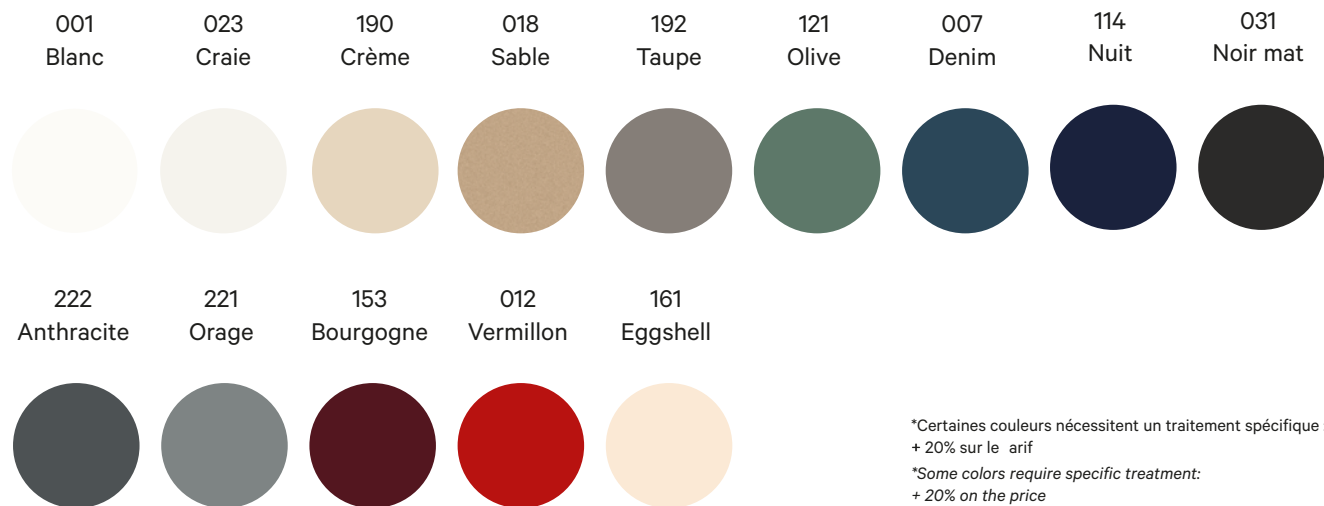

Légendes des pictogrammes Pictograms

- | | | | | | |
|--|--|---|---|-------------------------------|--|
| Usage exclusif à l'intérieur.
Only for indoor use. | Produit à monter. Visserie et clés de montage fournies.
Product to assemble. Screws and allen key provided. | Pose de renforts sur l'envers des plateaux.
Table base reinforced for solidity and flatness. | Possibilité d'intégrer un tiroir dans le plateau.
Possibility to integrate a drawer. | Pied effilé.
Tapered legs. | Finitions brut vernis brillant et brut vernis fumé disponibles.
Raw steel shiny and raw steel smoky (n°020 & 241) available |
| Usage possible à l'extérieur.
Possibility to use outdoor. | | Pied droit.
Straight legs. | Modèle empilable.
Stacking model. | | |

Designers



Luc Jozancy
avantpremiere.fr

Accompagne la marque depuis ses débuts et est à l'origine de la création des gammes Zef, Hegoa, et des tables basses Galets dont le succès ne se dément pas depuis plus de dix ans! Après une formation à l'ESAG Penninghen, Beaux-Arts de Bourges et l'Ensad Paris, il crée le studio Avant Première en 1988, au sein duquel il est directeur du département design produit. Références: Groupe Seb, Dynastar, Alstom, Boiron... ainsi que ☺ depuis 2005! Récompenses récentes: En 2013, Good Design Award, Japon pour Tefal. En 2009, Étoile de l'observateur du design pour Effia, vélos en libre-service et Refurbishment of the Year pour la rénovation intérieure du TGV Thalys.

Luc Jozancy assists ☺ since its creation and designed the Zef, Hegoa collection, also the Galets low tables whose success continues for 10 years! He ESAG Penninghen, Beaux Arts de Bourges and Ensad Paris (1985) — Industrial designer Diploma. Luc began his career at the Agency Solus working with companies from vastly different fields, among them Danone, Yves Saint Laurent, Nathan and Plastic Omnium. Creation of the Avant-Première design studio in Lyon in 1988, working as the head of the product Design department. His references are: Groupe Seb, Dynastar, Alstom, Boiron, and ☺ since 2005! In 2013, Luc received a Good Design Award, Japan for Tefal. In 2009, he got the Étoile de l'observateur du design for Effia, Bikes and Refurbishment of the year for TGV thalys interior renovation.



Constance Guisset
constanceguisset.com

Après une formation à l'ESSEC, IEP Paris, un an au parlement de Tokyo, ENSCI — Les Ateliers, elle crée le Studio Constance Guisset en 2007. Son travail s'articule autour d'une réflexion sur l'illusion visuelle et la surprise. Elle crée des objets légers, animés, dont l'élégante fluidité peut susciter l'étonnement et provoquer un instant d'évasion par le rêve. **Références:** Petite friture, Le Via, Molteni, Moustache, Louis Vuitton Malletier, Pallucco, Nodus, Fontana Arte, Groupe Accor... Créateur de l'année Now! design à vivre et Audi talent Awards en 2010. Janus du mobilier en 2014 pour la table Ankara fabriquée par ☺. Le musée des Arts décoratifs de Paris a consacré une exposition à son travail du 14 novembre 2017 au 11 mars 2018.

Constance studied Business and economics at ESSEC and IEP Paris, spent a year at the parliament of Tokyo, and got a ENSCI Diploma — Les Ateliers. She set up her own studio in 2007. Her work revolves around a philosophy of visual illusion and surprise. She creates light, lively objects whose elegant fluidity may arouse a feeling of surprise and be a springboard for a moment's daydreaming. Her references are: Petite Friture, Le Via, Molteni, Moustache, Louis Vuitton Malletier, Pallucco, Nodus, Fontana Arte, Groupe Accor... She was entitled Designer of the Year at the Now! Design à Vivre and Audi Talents Awards in 2010. In 2014, she was given a Janus de l'industrie for the Ankara collection manufactured by ☺.



Quaglio Simonelli
quagliosimonelli.com

Formation: Università del Progetto de Reggio Emilia, Italie. **Expérience:** après des débuts en Italie Manuela Quaglio et Andrea Simonelli sont appelés à rejoindre le Tim Thom (centre de création de Thomson Multimédia). Manuela dirigera le design stratégique mondial de TCL pendant dix ans. Création du studio de design Quaglio Simonelli en 2011. **Références:** Barilla, Mandarina Duck, Ligne Roset, L'Oréal, Sintesi et Debi, Alessi, My Fox... **Récompenses:** Red Dot Product Design Award. IF Product Design Award. HKDA Award. Kapok Prize. Étoile de l'Observateur. Janus de l'industrie. Plusieurs de leurs produits font partie de la collection du Fond national d'art contemporain au Centre Georges Pompidou, Paris.

Education: Università del Progetto, in Reggio Emilia, Italy. Career: after their start in Italy, Manuela quaglio and Andrea Simonelli are called to join as product designers the Tim Thom, (creative center of Thomson Multimedia). Manuela lead the World Strategic Design of TCL, will last over ten years. In 2011, they decided to create their design studio, signed Quaglio Simonelli. References: Barilla, Mandarina Duck, Ligne Roset, L'Oréal, Sintesi et Debi, Alessi, My Fox... Awards: The International Red Dot Product Design Award. IF Product Design Award. the chinese HKDA Award. Kapok Prize. The French Étoile de l'Observateur. The Janus de l'Industrie. Several products they designed are now part of the collection of the National Foundation for Contemporary Art at the Centre Georges Pompidou, Paris.



Beaverhausen
beaverhausen.be | hausmerk.com

Formation: Autodidactes passionnés de design. Master en arts graphiques et publicité pour Mimy A. Diar. Bachelor en marketing et communication pour Ad Luijten. **Expérience:** Aménagement du magasin de chaussures Waffles à Bruxelles, fauteuil Royale pour Indera présenté au Salon du meuble de Milan en 2011. Création d'objets et accessoires à leur marque Hausmerk, tous made in Belgium.

Education: Mimy A. Diar: Master degree in graphic arts and publicity. Ad Luijten: Bachelor's degree in marketing communications. Career: The interior of Waffles sneaker delicacies in Brussel, the voluptuous armchair called Royale for Belgian manufacturer Indera who was presented at Salone Internazionale del Mobile in 2011. Designing and selling small home accessories directly through their own brand Hausmerk, exclusively made in Belgium.



Victoria Wilmotte
victoriawilmotte.fr

Victoria Wilmotte est passée par l'École Camondo et a obtenu en 2008 un master « design products » au Royal College of Art de Londres. Elle crée son propre studio VW Design en 2009 qui devient en 2012 le studio Victoria Wilmotte SAS. Elle vit et travaille à Paris. Parmi ses collaborations, on compte la création d'objets et de mobilier, mais aussi Philips, de Pury, Poliform... Victoria Wilmotte développe dès ses études un intérêt particulier pour les matériaux, les formes ainsi que les procédés de fabrication, industriels comme artisanaux. Cette fascination méthodique et minutieuse va lui permettre d'offrir un œil singulier sur l'univers domestique qui demeure aujourd'hui son domaine d'intérêt.

Victoria Wilmotte went to the Camondo School, an Interior design school in Paris; and graduated and obtained a master in Design Products at the Royal College of Art of London. She opened her studio in 2009. She lives and works in Paris. Victoria's Wilmotte's signature sounds now like a brand, through her personal creations and her collaboration with her clients including Ikea, Legrand, Made in Design, Poliform, La pierre de France, Classicon, LCDA, Piasa, Hachette éditeur... She has been working with the TORRI gallery since 2014 on more exclusive projects. She can deal with both industrial and customized projects like monumental tables or, more recently, the redesign of a parisian restaurant.



Julie Gaillard
juliegiaillard.com

Julie Gaillard détourne les objets pour créer du sens, réinterpréter les moments de vie qui leur sont associés, questionne leurs usages et les codes pour détourner l'individu de ses repères habituels. Pour nous aider à gommer les tensions de tous les jours, ramener du sourire et du plaisir à travers une forme, un geste nouveau. Nous faire prendre le temps de faire, de vivre et de voir autrement... C'est à travers des créations poétiques et légères qui ont une histoire et d'inviter chez soi pour adoucir les espaces, les gestes, les pensées et les cœurs. Pour Julie Gaillard, les objets sont vivants. Ce sont eux qui nous choisissent.

Julie Gaillard diverts objects to create meaning. She like to reinterpret the moments associated with them. She always questions uses and codes to disctract the individual from his usual points of reference. Her designs help us soothe away daily tensions and can bring back a smile through the pleasure of a form or a new gesture. They induce us to take the time to see and experience our environment differently. Daily routine can be tinted with humor through light and poëtic creations that tell a story. An object invited in our home can soften the space, our gestures, our thoughts and hearts. Julie designed for us the very much poëtic Halo console table and the Lines centerpiece.



Hugues Weill
hugues-weill.com

Hugues Weill a imaginé pour nous la bibliothèque modulaire Levant. Qui d'autre que le designer Hugues Weill pour dessiner une bibliothèque en boîtes ? C'est tout naturellement que Matière Grise a choisi de collaborer avec ce designer expérimenté en mobilier de rangement, notamment de par ses collaboration avec Drugeot Manufacture, sur de nombreuses créations en bois. La bibliothèque Levant est un vrai totem, une ode à la géométrie imparfaite ! Un tube et un socle supportent les blocs de différentes tailles. Les blocs sont perforés à plusieurs endroits, offrant une totale liberté quant à leur positionnement, et donc à l'allure générale de la bibliothèque. Ajoutez à cela la palette de couleurs Matière Grise... Il y a des chances que chaque Levant soit tout à fait unique.

Who esle than Hugues Weill to draw a bookshelf with boxes? It was all so natural for us to pick this experimented designer in storage furniture to collaborate with. Hugues has in fact an impressive history in creating wooden pieces of furniture, mainly with the Drugeot manufacture. He designed for us the Levant bookshelf. It is a real totem, an ode to imperfect geometry ! A tube and a baseplate support blocks of different sizes, offering total freedom regarding their positioning, and thus regarding the general aspect of the bookshelf. Add to this masterpiece the color palette of Matière Grise to play with... Chances are high that each Levant might be absolutely unique.



Tamim Daoudi
tamimdaoudi.com

Pour Tamim Daoudi, l'objet raconte une histoire, il doit susciter une émotion. Aussi le concepteur et l'utilisateur sont-ils selon lui indéfectiblement associés dans l'acte créatif. Formé à Olivier de Serres et à la HEAR de Strasbourg, riche d'un itinéraire multiculturel qui l'a mené de Damas à Paris puis en Alsace, Tamim Daoudi réussit la parfaite synthèse entre les matériaux contemporains qu'il affectionne et les savoir-faire traditionnels qui le fascinent. Ses compétences s'exercent en design industriel et aménagement d'intérieurs. Tamim Daoudi embrasse les projets et innove à l'envi. Plus que tout, il aime amener les matériaux là où nul ne les attend, parfois même jusqu'à courber le béton, affiner l'acier, fusionner bois et métal... Sans jamais perdre de vue la philosophie de son processus créatif : simplicité et pertinence. Après un janus de l'industrie en 2014, il a remporté en 2018 pour sa lampe Fragment, éditée par Matière Grise, un Intramuros Design Award.

To Tamim Daoudi, objects tell a story and must spark off emotions. The young franco-syrian designer has always considered that the designer and the user are unwervingly linked to one another in creative actions. Tamim Daoudi was trained at the Olivier de Serres School and at Strasbourg's HEAR. His multicultural background served him well, taking him from Damas to Paris, and then to Alsace. He manages to perfectly combine contemporary materials, which he is fond of, with traditional know-how which he is fascinated by. He won in 2018 an Intramuros Design Award for his Fragment lamp, edited by MG.



Damien Carreres
damiencarreres.com

Diplômé de CRÉAD Lyon et de l'école Boulle, Damien Carreres commence à travailler seul, puis il est rejoint en 2012 par David Beltramelli, également diplômé de CRÉAD Lyon. Le binôme se fonde sur un dialogue permanent nourri par leurs personnalités distinctes. Ces architectes d'intérieurs travaillent pour une clientèle haut de gamme autant que pour des projets hôteliers, de restaurants et de boutiques. La création d'objets sur-mesure, déclinés dans différents domaines les a amenés depuis plus de 10 ans à développer le pôle design au sein de l'Agence. Dans une quête permanente du dessin pour la fonction et de la simplicité du trait pour le détail, ils développent des intérieurs et des objets personnalisés et personnalisables.

Graduated from the CREAD school in Lyon and from the Boulle School both, Damien Carreres started working on his own, and was quickly joined in 2012 by his school mate David Beltramelli, who also graduated from CREAD Lyon. The tandem is based on a permanent dialogue, fed by their distinctive personalities. These interior designers work for very high-end customers, for hotel and residential projects, but also for restaurants and stores. The creation of custom-made objects, declined in different sectors, has led them since 10 years to develop the product design branch of the Agency. They have designed for us the Bome storage system.



Ankara Suspensions
Pending lights
→ Page 32

Ankara Table basse
Coffee table
→ Page 31





Wind Tables basses
Coffee tables
→ Page 48

1. **Baguio** Table range revue
Magazine rack table
→ Page 65

3. **Flor** Set de trois tables basses
Set of three low tables
→ Page 49

2. **Bise** Set de trois guéridons
Set of three side tables
→ Page 64

4. **Alizé** Étagère rail à tiroirs
Shelf with drawers
→ Page 56



Take Chaise | Chair
→ Page 27

Loom Table triangle
Triangle table
→ Page 36

Zef Bureau | Desk
→ Page 26

Sirocco
Corbeille de rangement
Document tray
→ Page 26







Hegoo Étagère | Shelf
→ Page 43

Halo Console | Side table
→ Page 51



Rafale Console | *Console table*
→ Page 45

Diablo Table porte sac
Table with hooks
→ Page 61

Take 75
Chaise bar | Bar chair
→ Page 27







Ankara Tabouret | Stool
→ Page 32

Ankara Table bistrot
Bistrot table
→ Page 31

Ankara
Tabouret haut | *Bar stool*
→ Page 32



1. **Xlokk** Porte-manteau
deux pieds | Coat rack two legs
→ Page 57

2. **Ankara**
Mange Debout | Bar table
→ Page 31

3. **3 galets** Set de trois tables
basses | Set of three low tables
→ Page 34

Fragment Lampe à poser
au sol en trois modules
Floor lamp in 3 parts
→ Page 60





3 galets Set de trois tables basses | Set of three low tables
→ Page 34

Zonda H.105
Table mange debout | Bar table
→ Page 24

Take 75
Chaise bar | Bar chair
→ Page 27







Hegoo Table | Table
→ Page 40

Helm Fauteuil | Armchair
→ Page 37

Ponant Table basse
Coffee table
→ Page 46



Take Chaise I Chair
→ Page 27



22	Zef	55	Xlokk
27	Take	56	Bôme
28	Ankara	58	Fragment
33	Smack	59	Diablo
34	Galet	60	Mistral
36	Helm + Loom	62	Fleurs <i>Flowers</i>
38	Hegoa	63	Petit mobilier <i>Small furniture</i>
44	Rafale	64	Lueur
46	Ponant	65	Basics
47	Kuban	66	Centres de table <i>Table centerpieces</i>
47	Cers		
48	Wind		
49	Flor		
50	Cape		
51	Barber		
52	Levant		
53	Knick + Pampero		
54	Alizé		

Collections

Collections

Zef

Design
Luc Jozancy



Tables
Pieds de table
Consoles
Bancs
Bureau
Corbeille
Chaises

Tables
Table legs
Console tables
Benches
Desk
Document tray
Chairs



Zef

La collection Zef se décline dans une large gamme de plateaux combinables avec la hauteur de pieds de votre choix. Voir cahier technique | *The Zef collection is available in a wide range of top sizes to be mixed with the leg height of your choice. See technical guide.*

Choix de pieds effilés ou droits, sauf les hauteurs 30 cm, droits seulement | *Straight or tapered legs available, except height 30 cm, straight legs only.*

Ci-dessous, exemple avec un plateau 70 x 70 cm. *Below, example with a 70 x 70 cm top.*

1. **Zonda H.105** Table mange debout | *Bar table* (AC) (AL)

2. **Zonda H.90** Table mange debout | *Bar table* (AC) (AL)

3. **Zef H.75** Table | *Table* (AC) (AL)

4. **Zef H.45** Table basse *Low table* (AC) (AL)

5. **Zef H.30** Table extra-basse *Extra-low table* (AC) (AL)

6. Pied de table effilé seul *Table leg* (AC) Quatre hauteurs disponibles *Four heights available*



→ Page 70

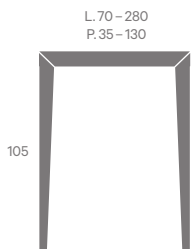

Zonda H.105

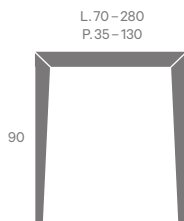

Zonda H.90

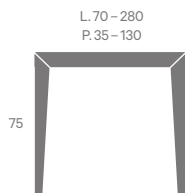

Zef H.75

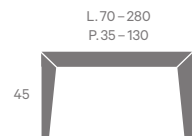

Zef H.45

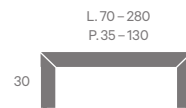

Zef H.30

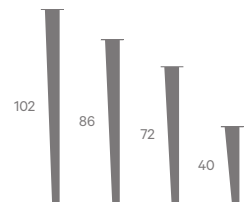

Pieds de table | *Table legs*

Exemples d'associations pieds et plateaux en hauteur 75 cm (non exhaustif, toutes les tailles en page 70 | Examples of top sizes with leg height 75 cm (non exhaustive, all sizes on page 70).



Plateau | Table top
80 × 80 cm



Plateau | Table top
100 × 100 cm



Plateau | Table top
130 × 130 cm



Plateau | Table top
130 × 60 cm



Plateau | Table top
120 × 80 cm



Plateau | Table top
180 × 100 cm



Plateau | Table top
220 × 100 cm



Plateau | Table top
180 × 65 cm



Plateau | Table top
80 × 35 cm



Plateau | Table top
130 × 35 cm



Plateau | Table top
195 × 35 cm

Zef

7. Console à tiroir
Console table with drawer (AC)
 Existe aussi sans tiroir
Also available without drawer
 (AC) (AL)
 Choix de pieds effilés
 ou droits | *Streight or tapered*
legs available

8. Banc | Bench (AC) (AL)
 Choix de pieds effilés
 ou droits | *Streight or tapered*
legs available

10. Bureau | Desk (AC)
 Choix de pieds effilés
 ou droits | *Streight or tapered*
legs available

9. Sirocco
 Corbeille de rangement
Document tray (AL)



7.



8.



9.



10.



→ Page 70 – 71

L. 80 – 195
P. 35



Console | Console table

L. 80 – 195
P. 35



Banc | Bench

120 x 80



Bureaux | Desks



Sirocco

Take

11. **Take** Chaise
Chair (AC) (AL)



11.

12. **Take 65** Chaise bar
Bar chair (AC) (AL)



12.

13. **Take 75** Chaise bar
Bar chair (AC) (AL)



13.

14. **Take 75 + tablette**
Chaise bar avec tablette
Bar chair with side top (AL)



14.

→ Page 72

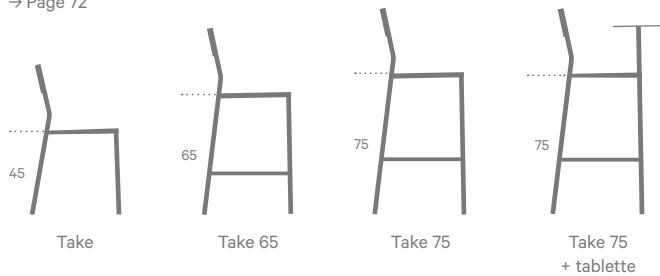

Ankara

Design

Constance Guisset



Chaise
Table repas
Table lounge
Table bistrot
Mange debout
Table basse
Chevet
Tabouret
Tabouret de bar
Suspensions
lumineuses

Chair
Dining table
Lounge table
Bistrot table
Bar table
Low table
Bedside table
Stool
Bar stool
Pending lights



Batchair



→ Page 73



45

Batchair

Ankara

1. Table repas | *Dining table*
Plateau rond ou carré 120
Round or square top 120 (AC)

2. Table repas | *Dining table*
Plateau rond ou carré 80
Round or square top 80 (AC)

3. Table lounge | *Lounge table*
Plateau rond ou carré
Round or square top (AC)

4. Table bistrot | *Bistrot table*
Plateau rond ou carré
Round or square top (AC)

5. Mange debout | *Bar table*
Plateau rond ou carré
Round or square top (AC)

6. Table basse | *Low table*
Plateau oval | *Oval table top* (AC)

7. Chevet | *Bedside table*
Plateau rond ou carré
Round or square top (AC)

Collection disponible pour certains modèles avec des plateaux bois et marbre . Vous référer au tarif *Wooden and marble table top available on some tables of this collection. Please refer to price list*



1.



2.



3.



4.



5.



6.



7.

→ Page 72

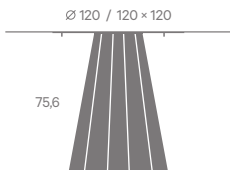

Table repas
Dining table

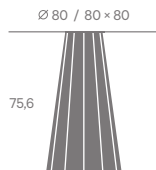

Table repas
Dining table

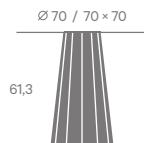

Table lounge
Lounge table

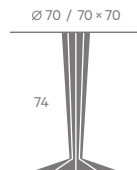
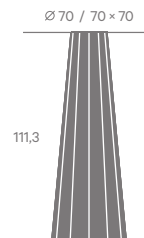

Table bistrot
Bistrot table



Mange debout
Bar table

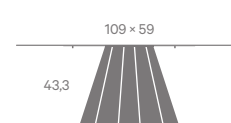
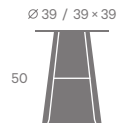

Table basse
Low table



Chevet
Bedside table

Ankara

8. Suspension Medium
Medium pending light (AC)



8.

9. Suspension Haute
Tall pending light (AC)



9.

10. Suspension Plate
Flat pending light (AC)



10.

11. Tabouret | Stool
Assise ronde | Round seat (AC)



11.

12. Tabouret haut | Bar stool
Assise ronde | Round seat (AC)



12.

→ Page 73

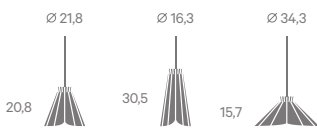

Suspensions | Pending lights

Medium
Medium

Haute
Tall

Plate
Flat



Tabouret
Stool

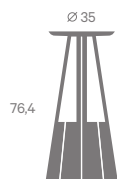

Tabouret Haut
Bar stool

Smack

Design
Luc Jozancy

Tabourets
Stools

Quatre hauteurs disponibles
Four heights available 



→ Page 73

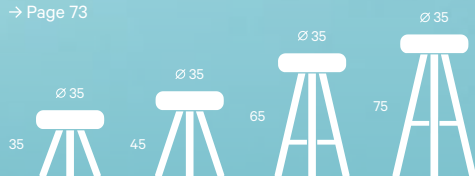

Smack

Galets

Design
Luc Jozancy

Tables basses
Low tables

Tables de bistrot
Bistrot tables

1. **Trois galets** Set de trois tables basses | Set of three low tables
Ⓐ Ⓒ

2. **Galet XL** Table basse
Low table Ⓐ

3. Exemples de mix table Galet XL + table Galet n°1 et/ou n°3
Examples Galet XL with Galet low table n°1 and/or n°3

Table 1



Table 2



Table 3



→ Page 73

63 × 59	75 × 58	64 × 57	120 × 80
39,9	38,7	37,5	38,7
Table 1	Table 2	Table 3	Galet XL

4. Tables de bistrot | *Bistro tables*
Deux hauteurs disponibles
Two height available (AC)

→ Page 73

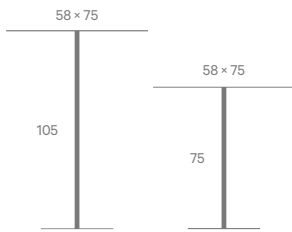

Tables de bistrot
Bistro tables

4.



Kona

Design
Luc Jozancy

Table basse
Low table

Trois pièces sur l'image,
non gigogne
Three pieces shown
(AC) (AL)

→ Page 73

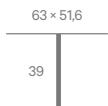

Kona



Helm + Loom

Design
Luc Jozancy

Fauteuil
Tables
Table basse

Armchair
Tables
Low table



1. Helm Fauteuil | Armchair (AL)

2. Loom Table triangle
Triangle table (AL)

3. Loom Table basse triangle
Triangle low table (AL)

4. Loom Table carré / rond
Square / round table (AL)



1.



3.



4.

→ Page 76

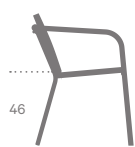

Helm

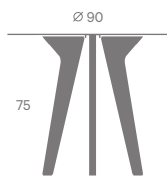

Loom
Table triangle
Triangle table

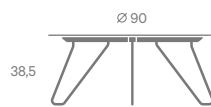

Loom
Table basse triangle
Triangle Low table

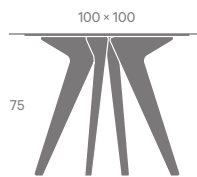

Loom
Table carrée / rond
Square / round table

Hegoa

Design
Luc Jozancy



Tables
Consoles
Bancs
Tabourets
Étagères
Desserte

*Tables
Console tables
Benches
Stools
Shelves
Trolley shelf*



Hegoa

La collection Hegoa se décline dans une large gamme de plateaux combinables avec la hauteur de pieds de votre choix. Voir cahier technique. *The Hegoa collection is available in a wide range of top sizes to be mixed with the leg height of your choice. See technical guide.*

1. Table mange debout *Bar table* ^{GA}

2. Table | *Table* ^{GA}

3. Table basse | *Low table* ^{GA}

4. Option roulettes disponible pour toutes les tables de hauteur 75 | *Wheel option available for leg height 75* ^{GA}



→ Page 74

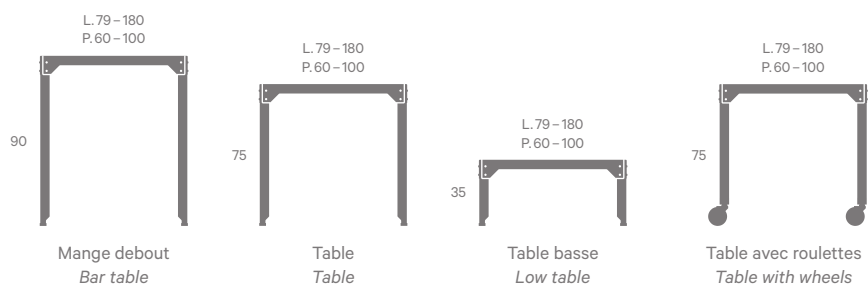

5. Console
Console table (GA)

6. Banc | Bench (GA)

7. Tabouret | Stool (GA)
Trois hauteurs disponibles
Available in three heights



5.



6.



7.



→ Page 74 – 75

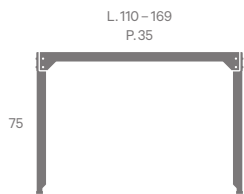

Console
Console table

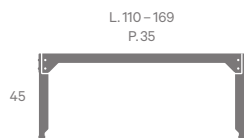

Banc | Bench

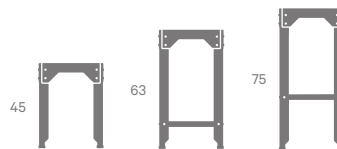

Tabourets | Stools

Hegoa



8. Étagère | Shelf
Nombre de niveaux et dimensions
au choix | Available in different
sizes (GA)



8.

9. Étagère percée + modules
amovibles | Drilled shelf
+ storage removable modules
Nombre de niveaux et dimensions
au choix | Available in different
sizes (GA)



9.



10.

→ Page 75

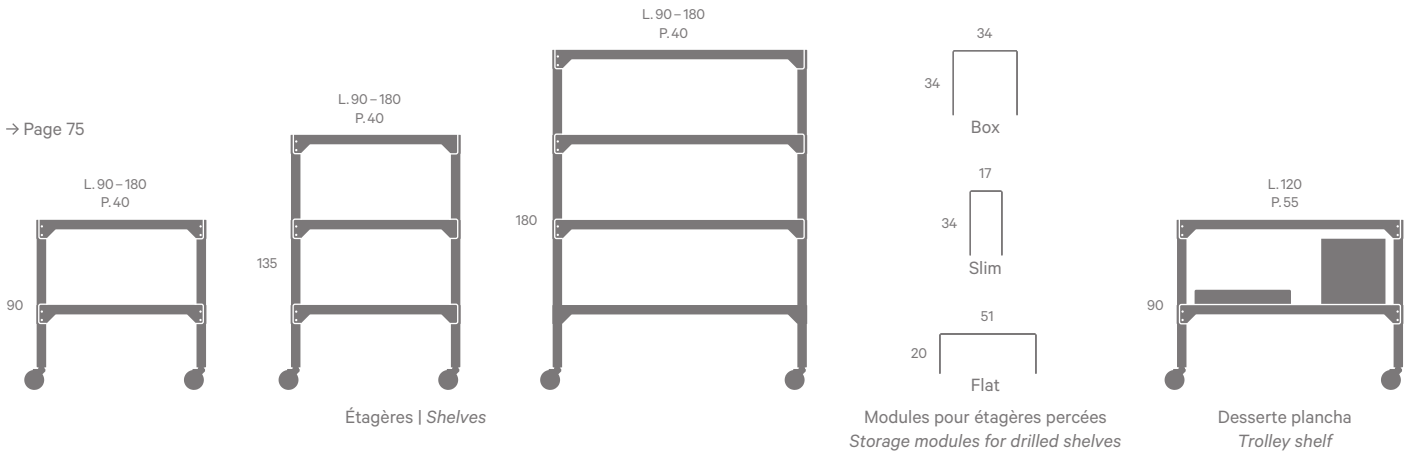

Étagères | Shelves

Modules pour étagères percées
Storage modules for drilled shelves

Desserte plancha
Trolley shelf

Rafale

Design
Luc Jozancy

Tables
Consoles
Tables basses

Tables
Console tables
Low tables



1. Table rectangulaire
Rectangle extending table (AC)

Aussi disponible | Also available:
— Table rectangulaire XL
XL Rectangle extending table (AC)
— Table carrée
Square extending table (AC)

2. Console | Console table (AC)

3. Console bureau
Desk console (AC)

4. Table basse | Low table (AC)



1.



2.



3.



4.



→ Page 76

80 × 80 / 120 × 80 / 180 × 100*

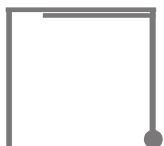

Table rectangulaire
Rectangle table

100 × 35*



Console

100 × 35*



Console bureau
Desk console

80 × 80*



Table basse
Low table

* Dimensions des plateaux
supérieurs, tables fermées.
Closed length.

Ponant

Design
Quaglio Simonelli

Table basse
Low table

Table basse | *Low table* 

Bout de canapé
Side table

Bout de canapé | *Side table* 



→ Page 77



Kuban

Table guéridon
Side table
©

Design
Luc Jozancy



→ Page 77

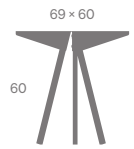

Table guéridon
Side table

Cers

Table basse
Coffee table

Table basse triple plateau
Triple top coffee table ©

Design
Luc Jozancy



→ Page 77

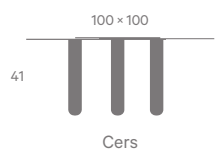

Cers

Wind

Design
Victoria Wilmotte

Tables basses
Coffee tables

Set de trois tables basses
Set of 3 nesting tables 



→ Page 77



Flor

Design
Beaverhausen

Tables basses
Low tables

Set de trois tables basses
Set of three low tables (AC)

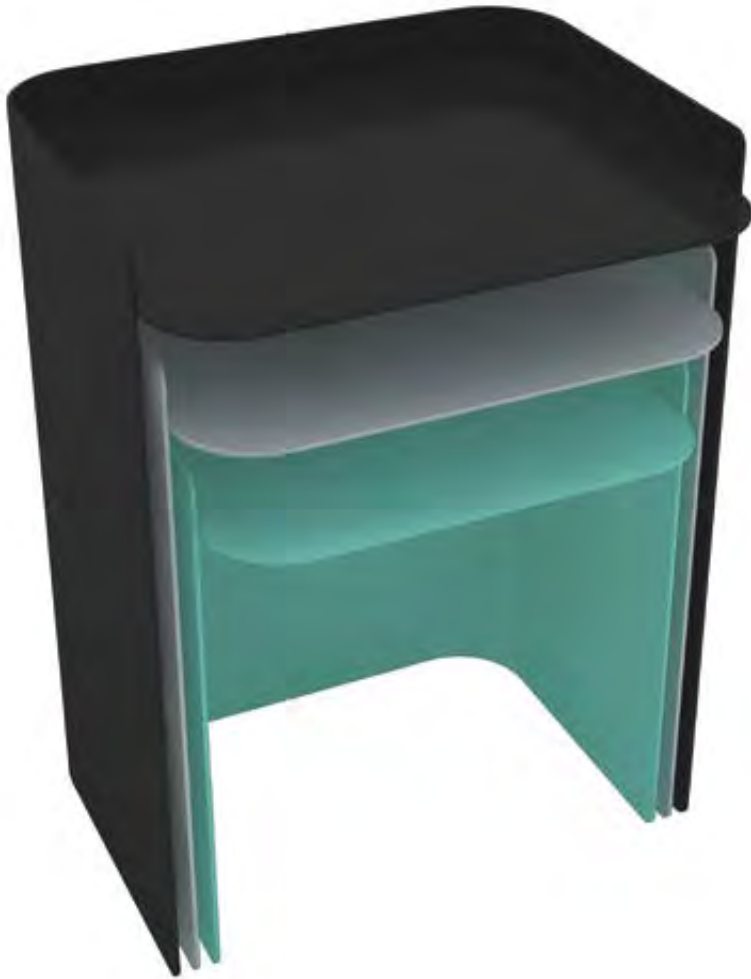

→ Page 77

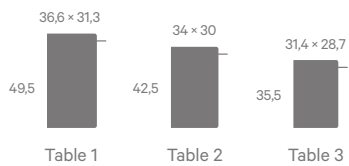

Cape

Design
Luc Jozancy

Console / rangement
Chevet / rangement
Jardinières

*Console table / storage
Bedside table / storage
Planters*

1. Chevet / rangement haut
High bedside table / storage (AC)

4. Jardinière rectangle basse
Low rectangle planter (GA)

2. Chevet / rangement bas
Low bedside table / storage (AC)

5. Jardinière carrée basse
Low square planter (GA)

3. Console rangement
Console table / storage (AC)

6. Jardinière carrée basse
Tall square planter (GA)



1.



2.



3.



4.



5.

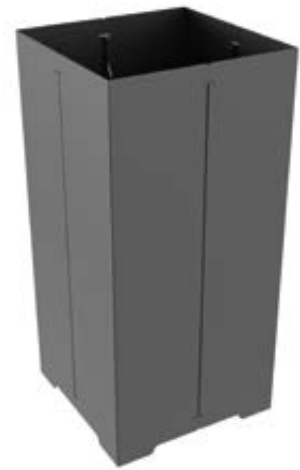

6.

→ Page 78

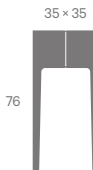

Chevet / rangement haut
High bedside table / storage

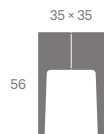

Chevet / rangement bas
Low bedside table / storage

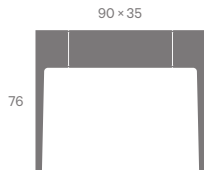

Console rangement
Console table / storage

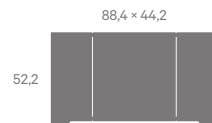

Jardinière rectangle basse
Low rectangle planter

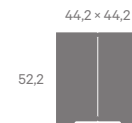

Jardinière carrée basse
Low square planter

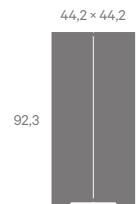

Jardinière carrée basse
Tall square planter

Barber

Design
Luc Jozancy

Meuble TV
TV stand

Tiroirs amovibles sur roulettes
Removable drawers on wheels
Deux tailles disponibles
Two sizes available (A)



→ Page 78

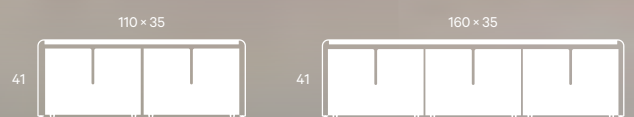

Barber

Levant

Design
Hugues Weill

Bibliothèque
Bookshelf

Étagère modulable
Modular bookshelf ©
Cinq modules à positionner
aléatoirement sur un tube central
*Five boxes to slip on a central
tube*



→ Page 79



Knick + Pampero

Design
Luc Jozancy

Étagères
Shelves

1. **Knick** Range magazines
Magazine shelves (AC)

2. **Knick** Range livres
Book shelves (AC)

3. **Knick** Combinaison possible
range livre et range magazine
Mix of book and magazine
shelves (AC)

4. **Pampero** Étagère | Shelf (AC)



1.



2.



3.



4.

→ Page 79

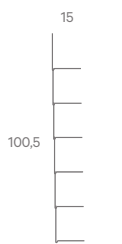

Knick
Range livres
Book shelves

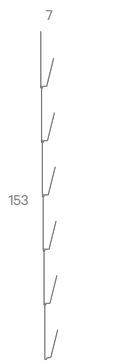

Knick
Range magazines
Magazine shelves

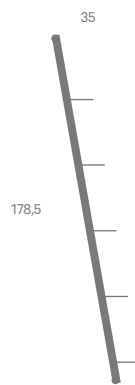

Pampero

Alizé

Design
Luc Jozancy

Étagère
Shelve

Étagère rail à tiroirs
Shelf with drawers
Deux longueurs disponibles
Two length available



→ Page 79

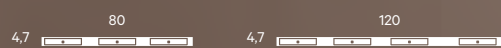

Alizé

Xlokk

Design
Luc Jozancy

Portes-manteaux
Coat racks

1. Porte-manteau deux pieds
à fixer au mur | Coat rack
two legs to be fixed on a wall (AC)

2. Porte-manteau quatre pieds
Coat rack four legs (AC)



→ Page 79

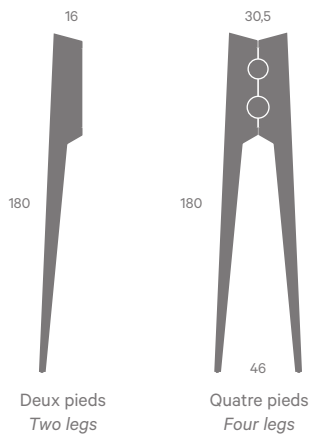

Bôme

Design
Damien Carreres

Système
de rangement
Storage system



Bôme est une collection de rangements modulaires. Elle est constituée de poutres-supports, en aluminium ou en frêne massif, sur lesquels des modules amovibles peuvent être suspendus. Trois modèles de barres et six modules disponibles. Pack pré-composés ou à l'unité.

Poutres: bois pour l'intérieur uniquement. L'aluminium peut être utilisé en extérieur. (AL)
Accessoires: acier pour l'intérieur uniquement. Traitement cataphorèse pour l'extérieur sur devis. (AC)

Bome is a modular storage collection. It includes poles in aluminum or in massive ash, on which can be plugged accessories. The poles are available in three lengths and there are six different accessories. Sold in pre-composed packs or individually.

*Poles: wood for indoor use only. Aluminum can be used outdoor. (AL)
 Accessories: steel, for indoor use only. Cataphoresis treatment for outdoor use on demand. (AC)*

Pack A



Pack B



Pack C



Pack D



Pack E



Pack F



Pack G



Pack H



Pack I



Pack J



→ Page 80



Petite boîte
Small box



Grande boîte
Big box

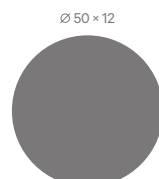

Miroir | Mirror



Tablette non percée
Shelf



Tablette percée | Pierced shelf
Douille et ampoule non fournies
Socket and lightbulb not provided



Patère
Hook



Poutres en bois de frêne ou en aluminium
Poles in ash or in aluminum

Fragment

Design
Tamim Daoudi

Lampe à poser
Floor lamp

Lampe à poser au sol
en trois modules
Floor lamp in 3 parts

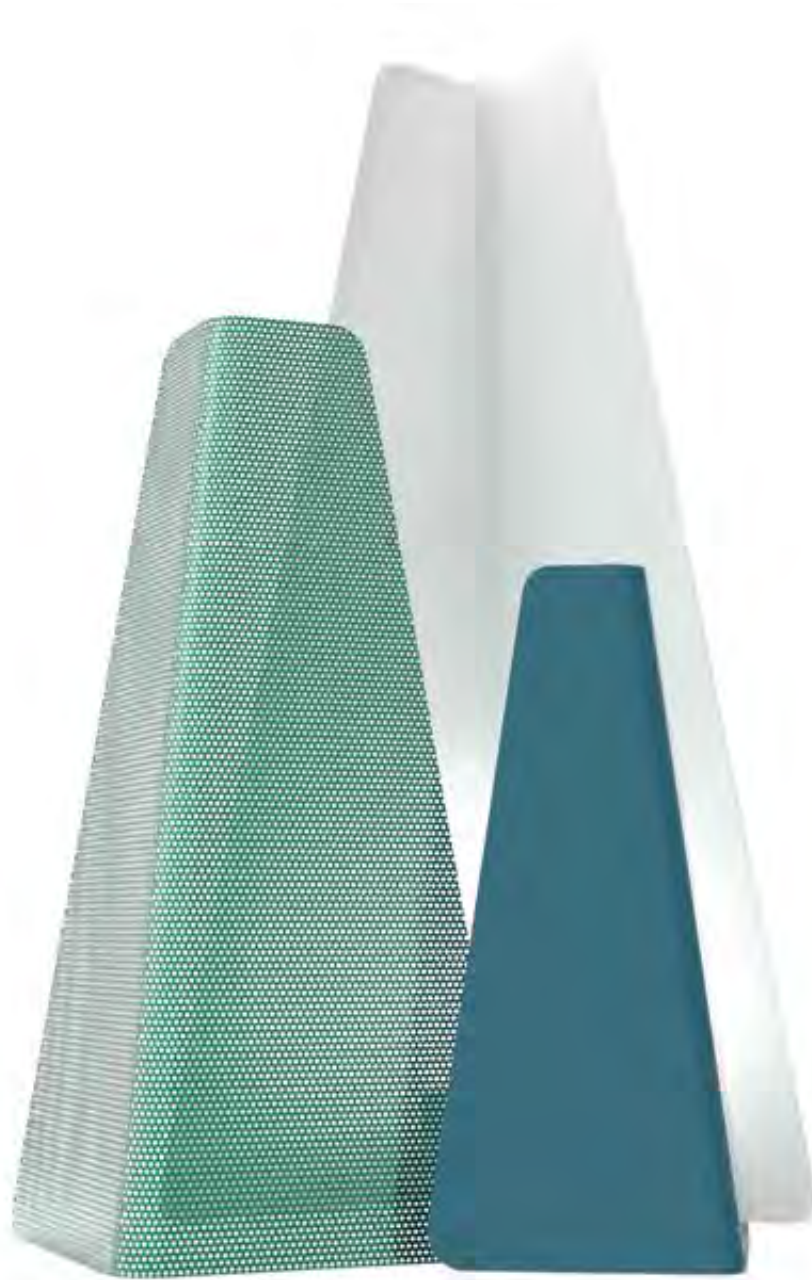

→ Page 80

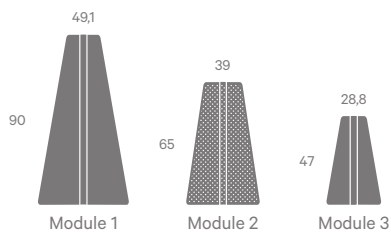

Diablo

Design
Luc Jozancy

Table porte sac
Table with hooks

Trois hauteurs disponibles
Three heights available 



→ Page 80



Mistral

Claustras
Screens

Design
Luc Jozancy

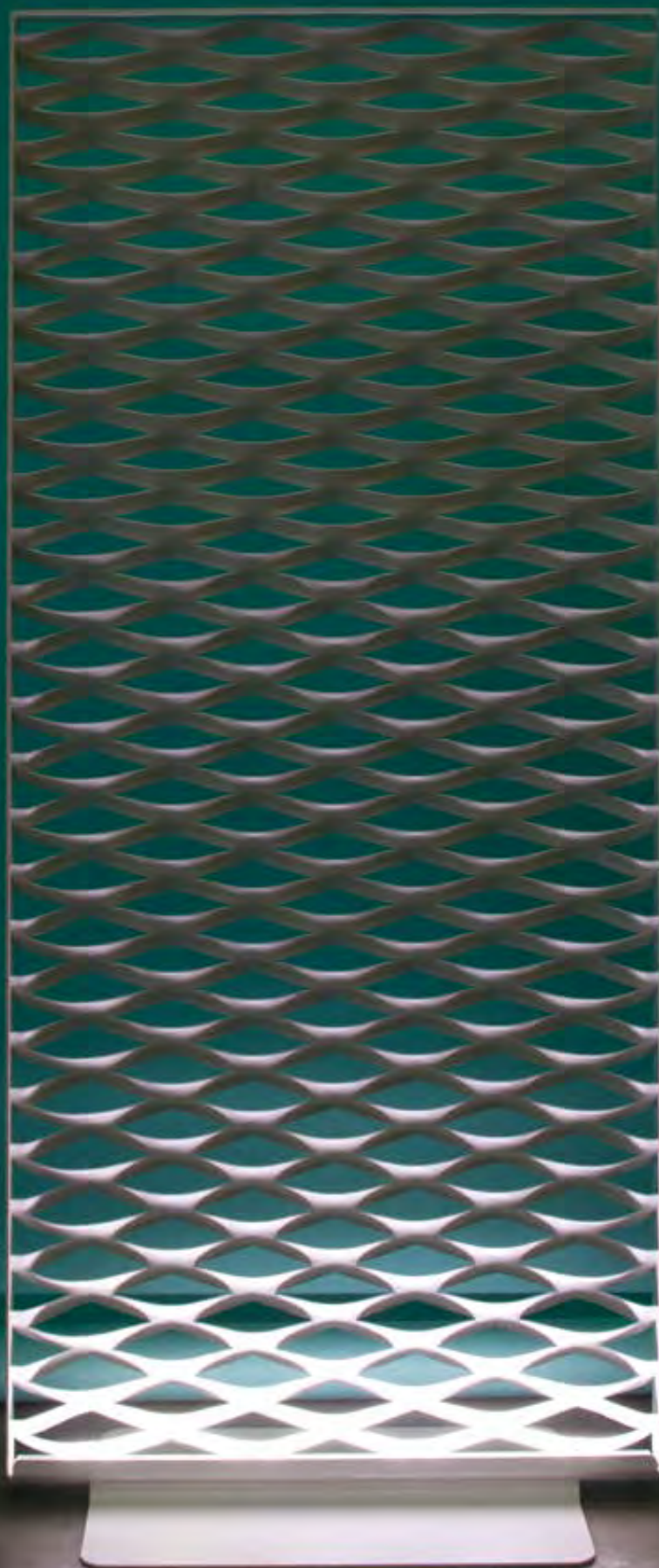

1. Clastra paravent trois volets
Screen three panels ^{AL}

En option | Option:
Éclairage leds blanc ou RVB
White or RGB Led lighting

2. Clastra sur socle
Screen on base ^{AL}



1.



2.

→ Page 81

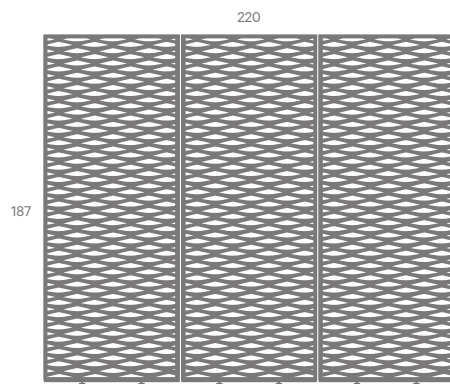

Clastra paravent trois volets
Screen three panels

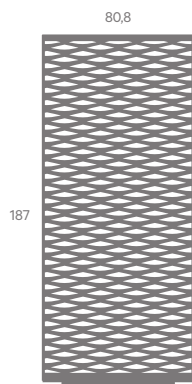

Clastra sur socle
Screen on base

Fleurs

Design
Luc Jozancy

Tables basses
Flower
low tables

- 1. **Bise** Set de trois guéridons
Set of three side tables (AC)
- 2. **Notus XL** Table basse
Low table (AC) (AL)
- 3. **Notus** Table basse | *Low table*
(AC) (AL)



1.

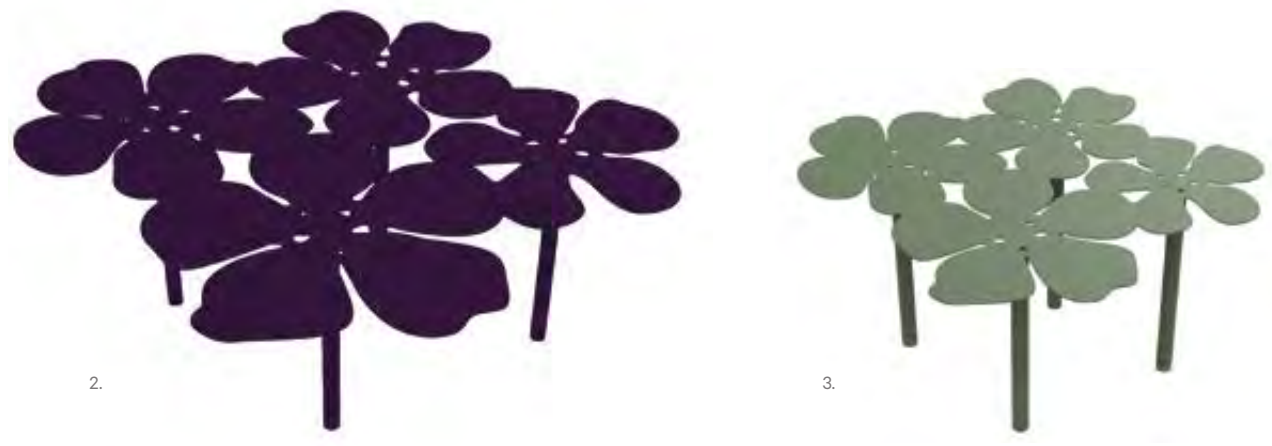

2.

3.

→ Page 81

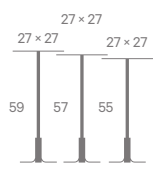

Bise 1 Bise 2 Bise 3

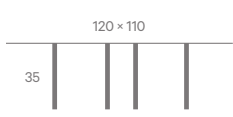

Notus XL



Notus

Petit mobilier

Design
Luc Jozancy

*Small
furniture*

- 1. **Leste** Bout de canapé
Sofa side unit (AL)
- 2. **Baguio** Table range revue
Magazine rack table (AL)
- 3. **Fun** Tabouret | Stool (AC)
- 4. **Solano** Table basse
porte revue | Low magazine
rack table (AC) (AL)



→ Page 81

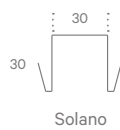
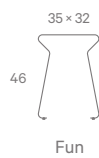
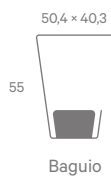
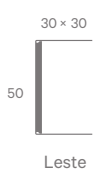

Lueur

Design
Luc Jozancy

Bougeoirs
Candle holders

Set de trois bougeoirs
Set of three candle holders



→ Page 81





Étagères
Porte tableaux
Patères
Plateaux

Shelves
Sledges
Hooks
Trays

- 1. **Oups** Étagère | Shelf ^{AC}
Deux longueurs disponibles
2 lengths available
- 2. **Zip** Rails porte tableaux
Sledges ^{AC}
3 longueurs disponibles
3 lengths available
- 3. **Clap** Patères | Hooks ^{AC}
- 4. **Crac** Set de 3 plateaux
Set of 3 trays ^{AC}

Basics

Design
Matière Grise

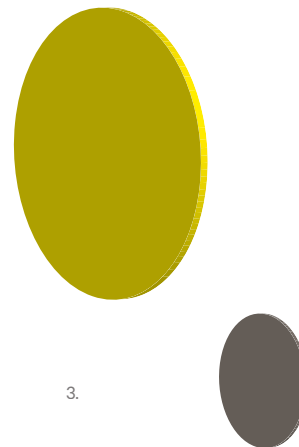

→ Page 82

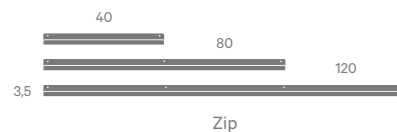
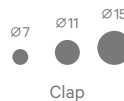
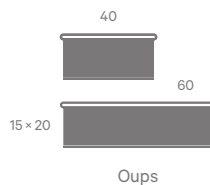
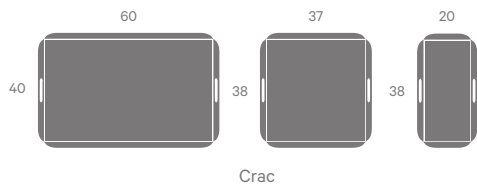

Centres de table

Table centerpieces
©

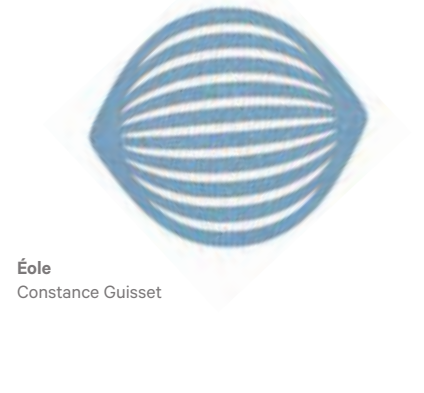
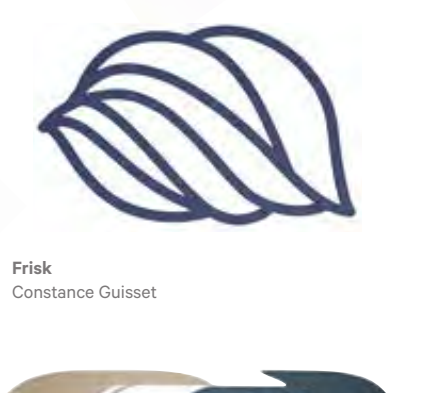

→ Page 82

38	36	30,6	27,5	38	36	33	32	29,2	34,7
Lips	Bora	Baguette	Pixel	Cyclone	Eurus	Simoon	Frisk	Eole	Lines

Technical guide

Légendes des pictogrammes | Pictograms

→ Rabat de couverture et page 1

On inside cover and page 1

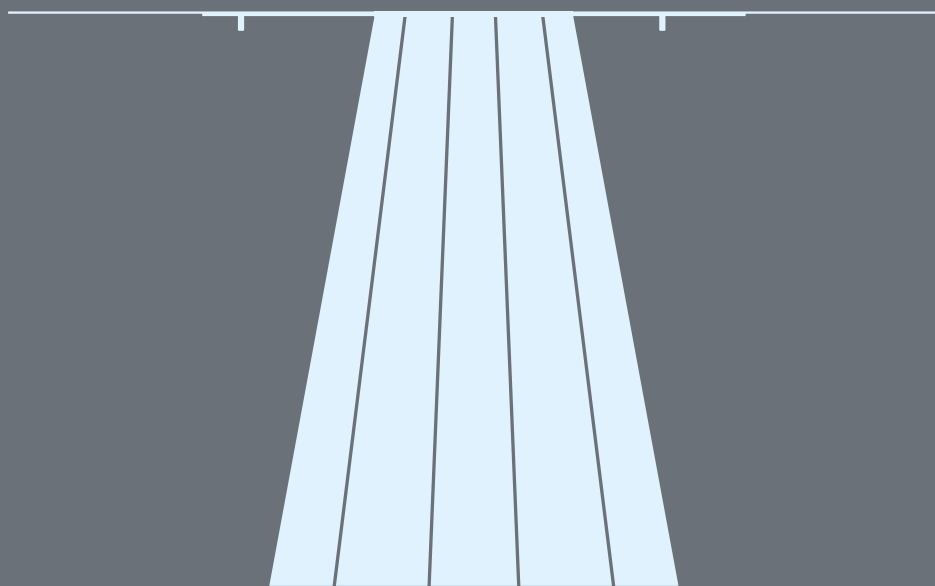

Cahier
technique

Zef

Tables, bancs et consoles | Tables, benches and console tables

Plateaux disponibles | Table top available:



Hauteurs de pieds disponibles | Available leg heights:



Tableau des combinaisons possibles:
Mix and match tops with leg heights:

Ⓐ = ☐ Ⓐ = ⚙

Embouts de pieds réglables vissés en Polyéthylène.
A polyethylene adjustable cap is fitted on each leg.

Tailles plateaux Table top sizes	Hauteurs des pieds Leg heights				
	30	45	75*	90	105
70 × 70	Ⓐ Ⓐ ⊗ ⋄	Ⓐ Ⓐ ⊗ ⋄	Ⓐ 23 kg Ⓐ 8 kg ⊗ ⋄	Ⓐ Ⓐ ⊗ ⋄	Ⓐ Ⓐ ⊗ ⋄
80 × 80	Ⓐ Ⓐ ⊗ ⋄	Ⓐ Ⓐ ⊗ ⋄	Ⓐ 24 kg Ⓐ 8 kg ⊗ ⋄	Ⓐ Ⓐ ⊗ ⋄	Ⓐ Ⓐ ⊗ ⋄
100 × 100	Ⓐ Ⓐ ⊗ ☐	Ⓐ Ⓐ ⊗ ☐	Ⓐ 27 kg Ⓐ 10 kg ⊗ ☐	Ⓐ Ⓐ ⊗ ☐	Ⓐ Ⓐ ⊗ ☐
130 × 130	Ⓐ Ⓐ ⊗ ⋄ ☐	Ⓐ Ⓐ ⊗ ⋄ ☐	Ⓐ 40 kg Ⓐ 14 kg ⊗ ⋄ ☐	Ⓐ Ⓐ ⊗ ⋄ ☐	Ⓐ Ⓐ ⊗ ⋄ ☐
130 × 60	Ⓐ Ⓐ ⊗ ⋄ ☐	Ⓐ Ⓐ ⊗ ⋄ ☐	Ⓐ 27 kg Ⓐ 9 kg ⊗ ⋄ ☐	Ⓐ Ⓐ ⊗ ⋄ ☐	Ⓐ Ⓐ ⊗ ⋄ ☐
120 × 80	Ⓐ Ⓐ ⊗ ⋄ ☐	Ⓐ Ⓐ ⊗ ⋄ ☐	Ⓐ 32 kg Ⓐ 10 kg ⊗ ⋄ ☐	Ⓐ Ⓐ ⊗ ⋄ ☐	Ⓐ Ⓐ ⊗ ⋄ ☐
140 × 90	Ⓐ Ⓐ ⊗ ☐	Ⓐ Ⓐ ⊗ ☐	Ⓐ 37 kg Ⓐ 15 kg ⊗ ☐	Ⓐ Ⓐ ⊗ ☐	Ⓐ Ⓐ ⊗ ☐
180 × 65	Ⓐ Ⓐ ⊗ ☐	Ⓐ Ⓐ ⊗ ☐	Ⓐ 42 kg Ⓐ 14 kg ⊗ ☐	Ⓐ Ⓐ ⊗ ☐	Ⓐ Ⓐ ⊗ ☐
180 × 90	Ⓐ Ⓐ ⊗ ⋄ ☐	Ⓐ Ⓐ ⊗ ⋄ ☐	Ⓐ 46 kg Ⓐ 18 kg ⊗ ⋄ ☐	Ⓐ Ⓐ ⊗ ⋄ ☐	Ⓐ Ⓐ ⊗ ⋄ ☐
220 × 100	Ⓐ Ⓐ ⊗ ☐ ☐	Ⓐ Ⓐ ⊗ ☐ ☐	Ⓐ 60 kg Ⓐ 26 kg ⊗ ☐ ☐	Ⓐ Ⓐ ⊗ ☐ ☐	Ⓐ Ⓐ ⊗ ☐ ☐
280 × 115	Ⓐ Ⓐ ⊗ ☐ ☐	Ⓐ Ⓐ ⊗ ☐ ☐	Ⓐ 78 kg Ⓐ 29 kg ⊗ ☐ ☐	Ⓐ Ⓐ ⊗ ☐ ☐	Ⓐ Ⓐ ⊗ ☐ ☐
80 × 35	Ⓐ Ⓐ ⊗ ⋄	Ⓐ Ⓐ ⊗ ⋄	Ⓐ 17 kg Ⓐ 7 kg ⊗ ⋄	Ⓐ Ⓐ ⊗ ⋄	Ⓐ Ⓐ ⊗ ⋄
103 × 35	Ⓐ Ⓐ ⊗ ☐	Ⓐ Ⓐ ⊗ ☐	Ⓐ 20 kg Ⓐ 8 kg ⊗ ☐	Ⓐ Ⓐ ⊗ ☐	Ⓐ Ⓐ ⊗ ☐
120 × 35	Ⓐ Ⓐ ⊗ ⋄	Ⓐ Ⓐ ⊗ ⋄	Ⓐ 20 kg Ⓐ 9 kg ⊗ ⋄	Ⓐ Ⓐ ⊗ ⋄	Ⓐ Ⓐ ⊗ ⋄
120 × 35 + ☐	•	•	Ⓐ 23 kg ⊗ ⋄	Ⓐ ⊗ ⋄	Ⓐ ⊗ ⋄
130 × 35	Ⓐ Ⓐ ⊗ ⋄	Ⓐ Ⓐ ⊗ ⋄	Ⓐ 21 kg Ⓐ 10 kg ⊗ ⋄	Ⓐ Ⓐ ⊗ ⋄	Ⓐ Ⓐ ⊗ ⋄
160 × 35	Ⓐ Ⓐ ⊗ ⋄	Ⓐ Ⓐ ⊗ ⋄	Ⓐ 25 kg Ⓐ 11 kg ⊗ ⋄	Ⓐ Ⓐ ⊗ ⋄	Ⓐ Ⓐ ⊗ ⋄
195 × 35	Ⓐ Ⓐ ⊗ ⋄	Ⓐ Ⓐ ⊗ ⋄	Ⓐ 27 kg Ⓐ 12 kg ⊗ ⋄	Ⓐ Ⓐ ⊗ ⋄	Ⓐ Ⓐ ⊗ ⋄

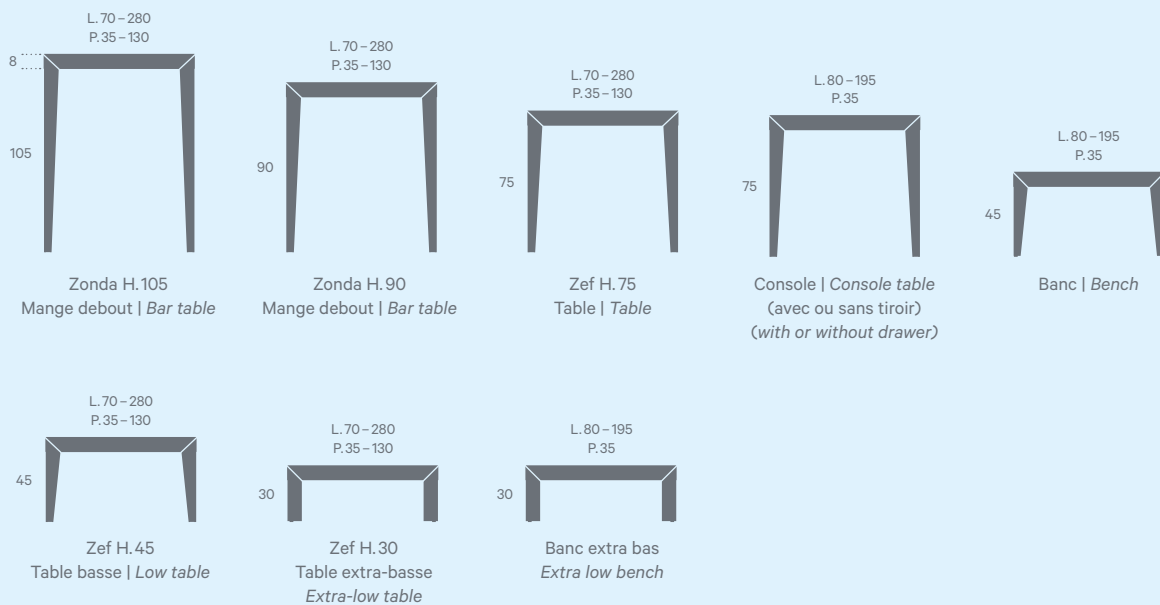
* Poids des tables hauteur 75 cm à titre indicatif
The weight of the tables height 75 cm are on an indicative basis

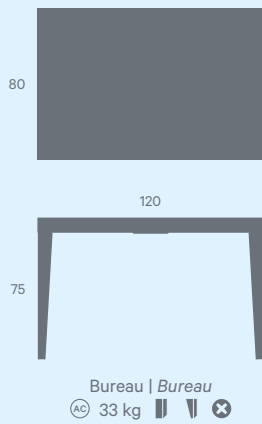

Équipé avec | Comes with:

- Un tiroir | One drawer ☐ 59,8 × 33 × 6 cm
- Modules au choix | Modules available:

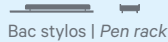

Pieds de table | Table legs
À fixer sur plateau en bois, stratifié...
To be used with a wooden top for instance
|| ⊗ | Ⓐ ⋄

Sirocco

Composez votre système de corbeille
comme vous le souhaitez.
Mix and match tops of your choice.

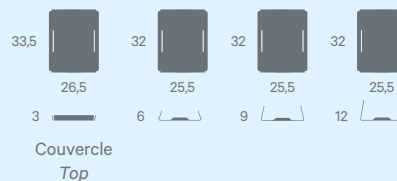
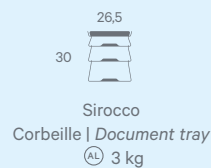

Take

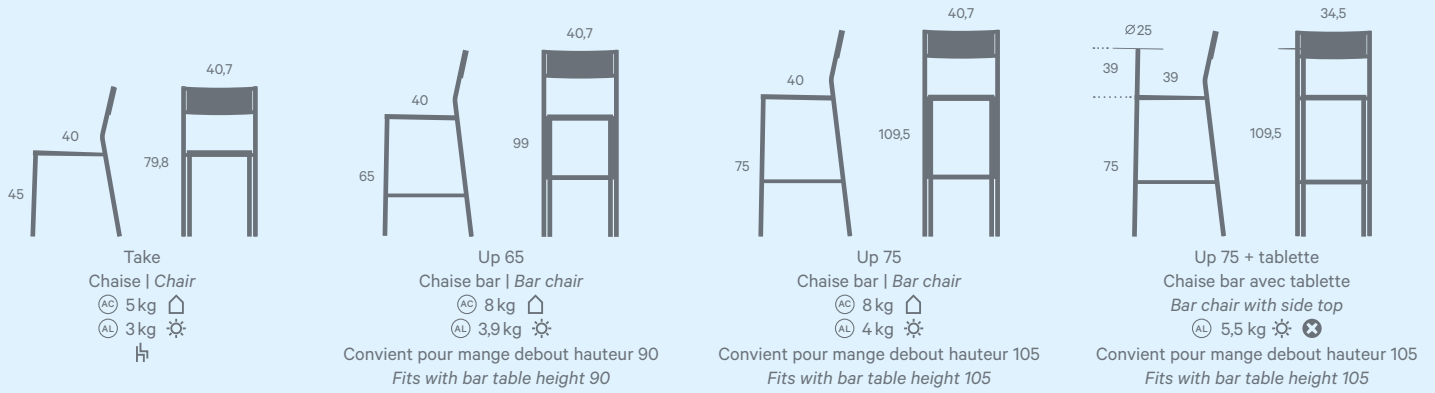

Patins de protection sous les quatre pieds
Protective pads under the four legs



Ankara

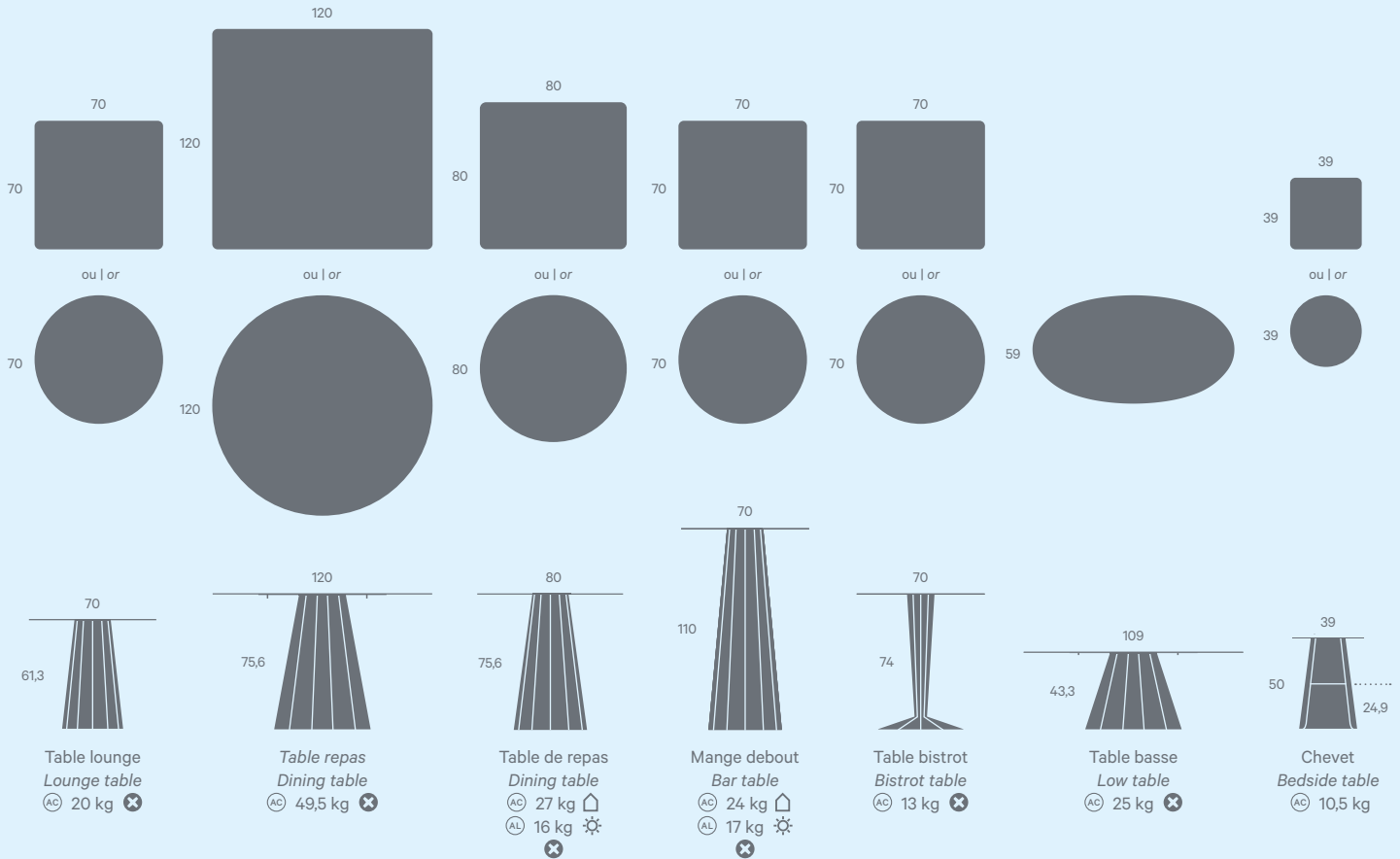

Épaisseur acier | Steel thickness 3 mm
Patins de protection sous les pieds | Protective pads under the legs

Batchair
Chaise | Chair
AC 5 kg

Tabouret
Stool
6,2 kg

Tabouret Haut
Bar stool
12 kg

Suspensions | Pending lights

Medium
Medium
1,1 kg

Plate
Flat
1,4 kg

Haute
Tall
1,2 kg

Patins de protection sous les pieds
Protective pads under legs
Assise chêne massif vernis mat anti tâche
Oak woodentop with anti-mark varnish
AC

Cable gris ou noir 2m | 2m of grey cable
Ampoule E27 non fournie | E27 light bulb not provided
AC

Smack

36 37 38 40

35 45 65 75

7,5 kg 8,5 kg 10 kg 11 kg

Tabourets | Stools
Assise chêne US massif, finition huilée
Seat in massive oak, oiled
AC

Kona

516 63 39,4

Table basse | Low table
AC 25 kg
AL 5,5 kg
Ø socle | base 38 cm
Ø tube | tube 2.5 cm

Galets

59 58 57 80 58 58

63 75 64 120 75 75

39,9 38,7 37,5 38,7 105 75

Table 1 Table 2 Table 3 Galet XL

24 kg 23 kg

3 galets

Table basse | Low table
AC 32,5 kg
Ø socle | base 52 cm
Ø tube | tube 6 cm

Tables de bistrot | Bistrot tables
AC

Set de trois tables basses | Set of three low tables
AC 75 kg (les trois tables | three tables)
AL 16 kg (les trois tables | three tables)
Ø socle | base 38 cm
Ø tube | tube 2.5 cm

Option cataphorèse pour usage extérieur
sur demande
Cataphoresis treatment for outdoor use,
on demand

Hegoa

Tables, consoles, bancs et tabourets | Tables, console tables, benches and stools

Plateaux disponibles | Available table tops:

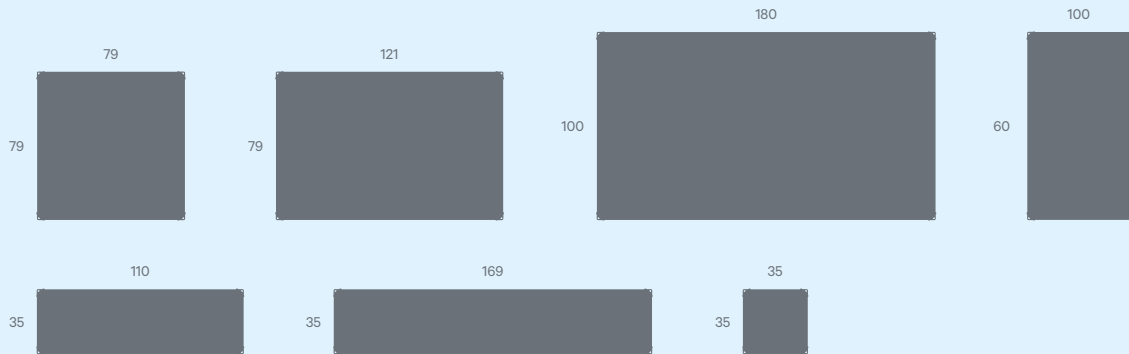

Hauteurs de pieds disponibles | Available leg heights:



Tableau des combinaisons possibles:

Mix and match tops with leg heights:

Tailles plateaux Table tops sizes	Hauteurs des pieds Leg heights					
	35	45	63	75*	90	75 roulettes wheels
79 × 79	GA ☀️ ❌	GA ☀️ ❌	•	GA 17 kg ☀️ ❌	GA ☀️ ❌	GA ☀️ ❌
121 × 79	GA ☀️ ❌	GA ☀️ ❌	•	GA 23 kg ☀️ ❌	GA ☀️ ❌	GA ☀️ ❌
180 × 100	GA ☀️ ❌	GA ☀️ ❌	•	GA 33 kg ☀️ ❌	GA ☀️ ❌	GA ☀️ ❌
100 × 60	GA ☀️ ❌	GA ☀️ ❌	•	GA 17 kg ☀️ ❌	GA ☀️ ❌	GA ☀️ ❌
110 × 35	GA ☀️ ❌	GA ☀️ ❌	•	GA 13 kg ☀️ ❌	GA ☀️ ❌	GA ☀️ ❌
169 × 35	GA ☀️ ❌	GA ☀️ ❌	•	GA 18 kg ☀️ ❌	GA ☀️ ❌	GA ☀️ ❌
35 × 35	GA ☀️ ❌	GA ☀️ ❌	GA ☀️ ❌	GA 8 kg ☀️ ❌	GA ☀️ ❌	•

* Poids des tables hauteur 75 cm à titre indicatif

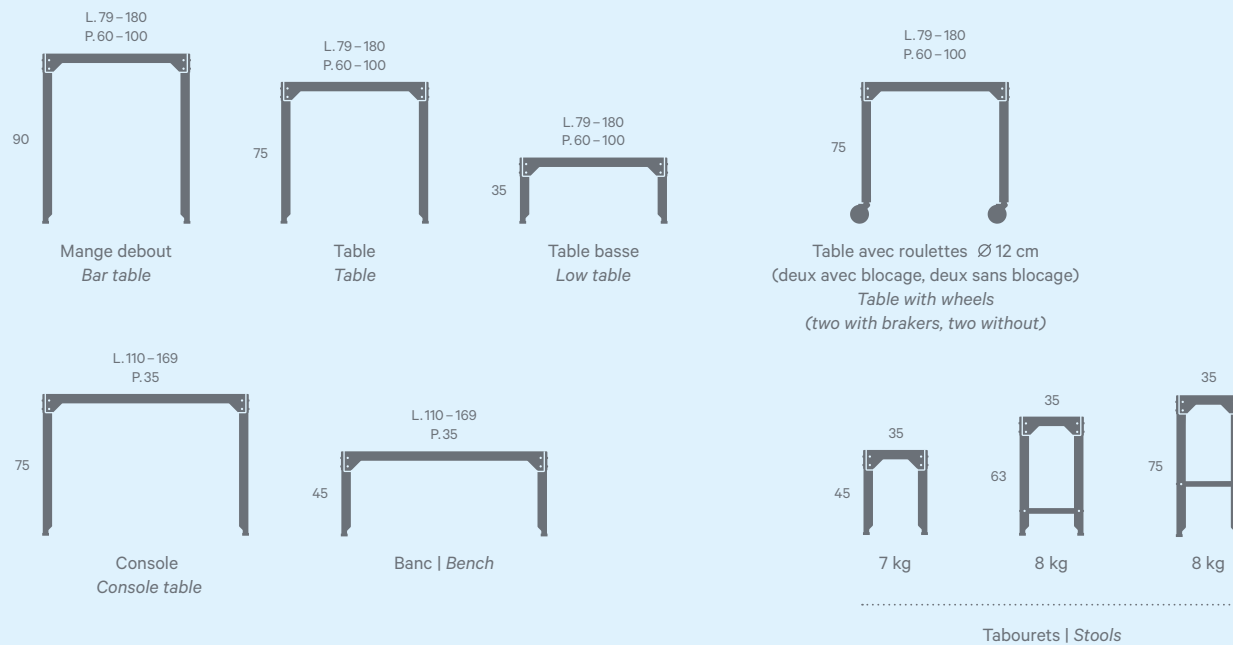
The weight of the tables height 75 cm are on an indicative basis

Étagères | Shelves

Deux choix possible:

- Non percées
- Percées pouvant recevoir des modules (perçage tous les 17 cm)

Two options available:

- No drilled
- Drilled for storage modules (drilled every 17 cm)

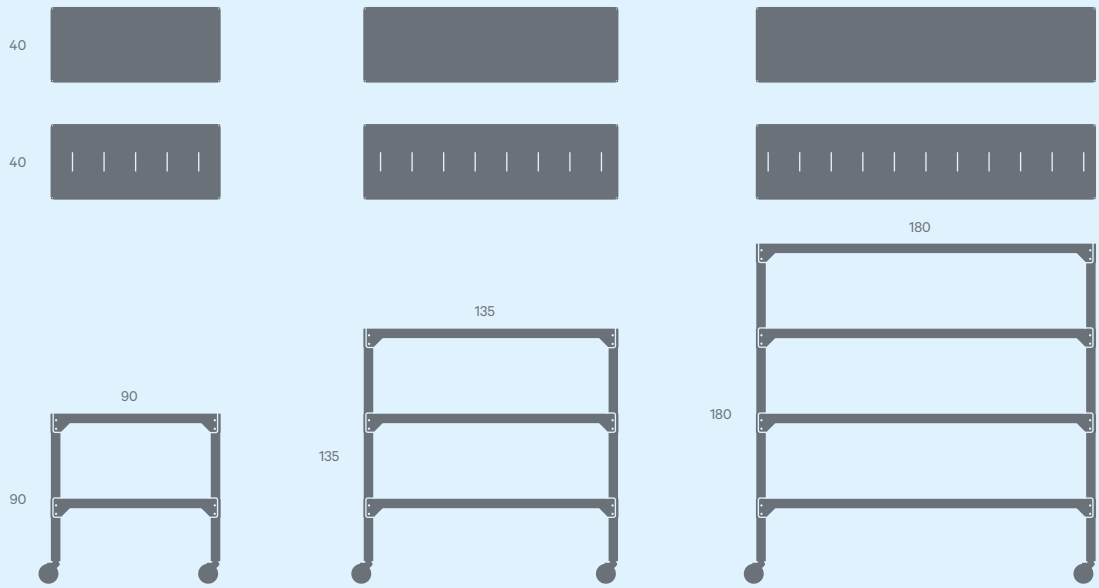

Étagères | Shelves



Étagères percées: il est nécessaire de toujours laisser un espace entre deux modules de rangement. Ne pas surcharger l'étagère de modules, pour un effet visuel optimal. Nombre de modules recommandés:

- Longueur 90 1 à 2 modules
- Longueur 135 1 à 3 modules
- Longueur 180 1 à 4 modules

Drilled shelving units: a space should always be left between two storage modules. For the most attractive visual effect do not overload the shelving unit with modules. We advise:

- Length 90 1 to 2 modules maximum
- Length 135 1 to 3 modules maximum
- Length 180 1 to 4 modules maximum

Tableau des combinaisons possibles:

Mix and match tops with leg heights:

Tailles plateaux Table tops sizes	Nombre de plateaux Number of tops		
	2 (H. 90)	3 (H. 135)	4 (H. 180)
40 × 90	GA 28 kg ⚙️ ❌	GA 34 kg ⚙️ ❌	•
40 × 135	GA 30 kg ⚙️ ❌	GA 45 kg ⚙️ ❌	GA 60 kg ⚙️ ❌
40 × 180	GA 37 kg ⚙️ ❌	GA 55 kg ⚙️ ❌	GA 70 kg ⚙️ ❌

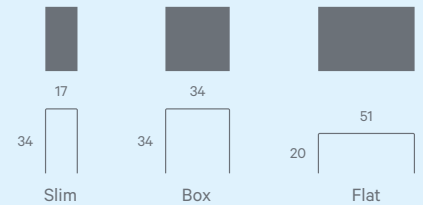

Modules amovibles pour étagères percées
Removable storage modules for drilled shelves
GA 7 kg ⚙️

**Desserte plancha
Trolley shelf**

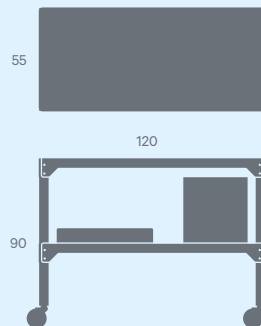

Desserte plancha avec roulettes Ø 12 cm (deux avec blocage, deux sans blocage)
Trolley shelf with wheels (two with brakers, two without)



Range bouteilles amovible
Removable bottle storage unit



Cache cube Butagaz® standard amovible | Removable gas bottle cover

GA 41 kg ⚙️ ❌

Helm

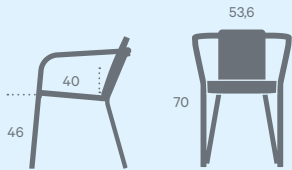

Fauteuil | *Armchair*
 (AL) 9 kg ☀️ 🚫

Le fauteuil peut s'utiliser avec ou sans coussin.
The armchair can be used with or without cushion.

Coussin dossier | *Backrest cushion*
 Coloris tissus outdoor déperlant: noir, blanc, orange. Nettoyage à l'eau avec une éponge humide. Pas de nettoyage à sec. Fixation du coussin sur le dossier par élastique et patte sur l'assise.

Outdoor water resistant fabric. Colours: black, white, orange. Cleaning with a wet sponge. No dry cleaning. Cushion to be fixed on the backrest with an elastic and on the seat with a removable system.

Loom

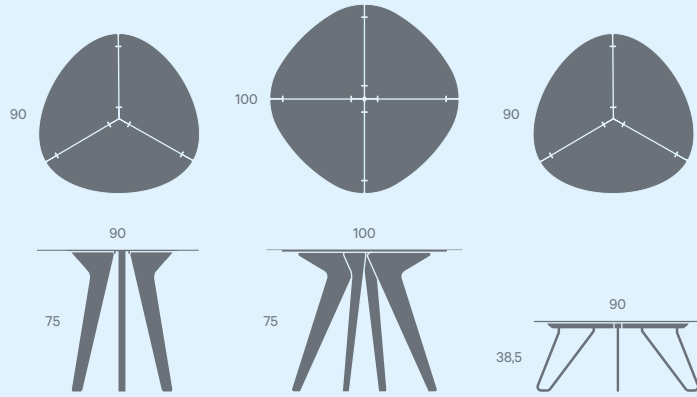
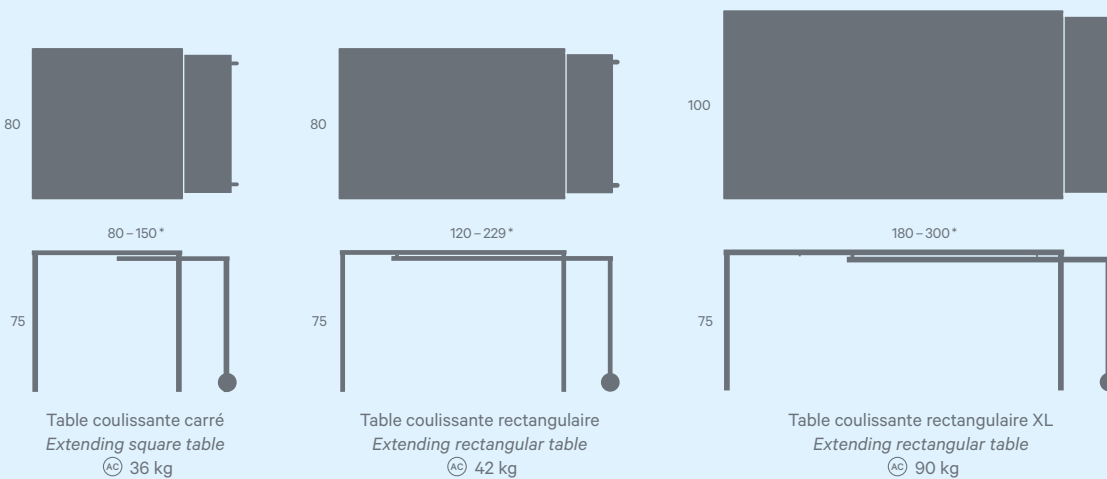

Table triangle
Triangle table
 Trois pieds caissonnés
Three angled legs
 (AL) 11,5 kg ☀️ 🚫

Table carrée/rond
Square/round table
 Quatre pieds caissonnés
Four angled legs
 (AL) 20 kg ☀️ 🚫

Table basse triangle
Triangle low table
 Pieds inox | *Stainless steel legs*
 (AL) 13 kg ☀️ 🚫

Rafale



* Taille fermée – ouvert
Size closed – open

Arrêt position intermédiaire grâce à une encoche au milieu de la trajectoire du plateau inférieur.
Integrated block system half way of the opening of the table.

Roulettes sous deux pieds | *wheels on two legs* Ø 10 cm
 Pieds tube carré | *Square legs* 2,5 x 2,5 cm

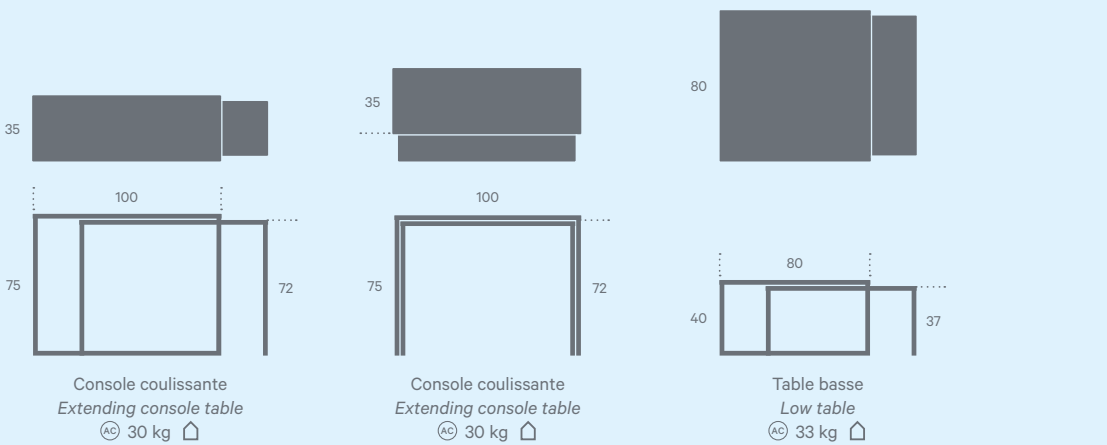

Console coulissante
Extending console table
 (AL) 30 kg 🏠

Console coulissante
Extending console table
 (AL) 30 kg 🏠

Table basse
Low table
 (AL) 33 kg 🏠

Ponant

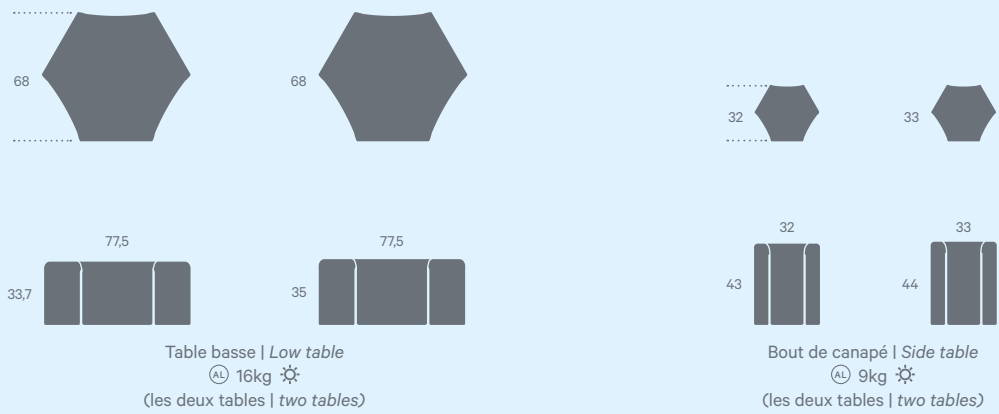

Kuban

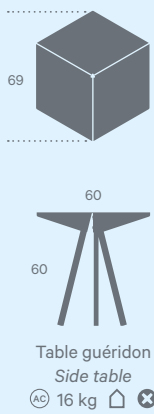

Cers

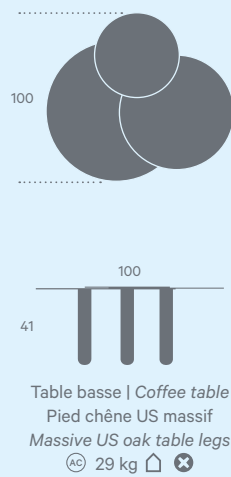

Wind

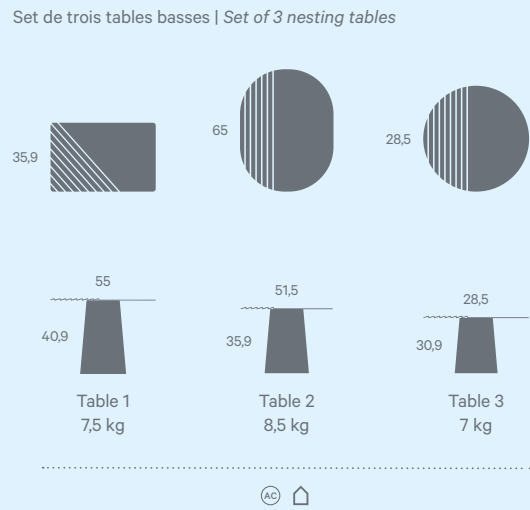

Flor

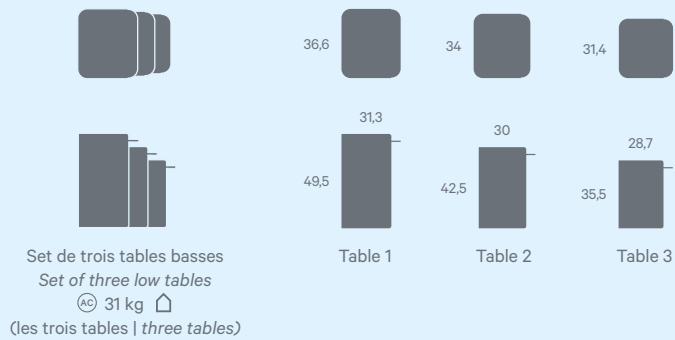

Cape

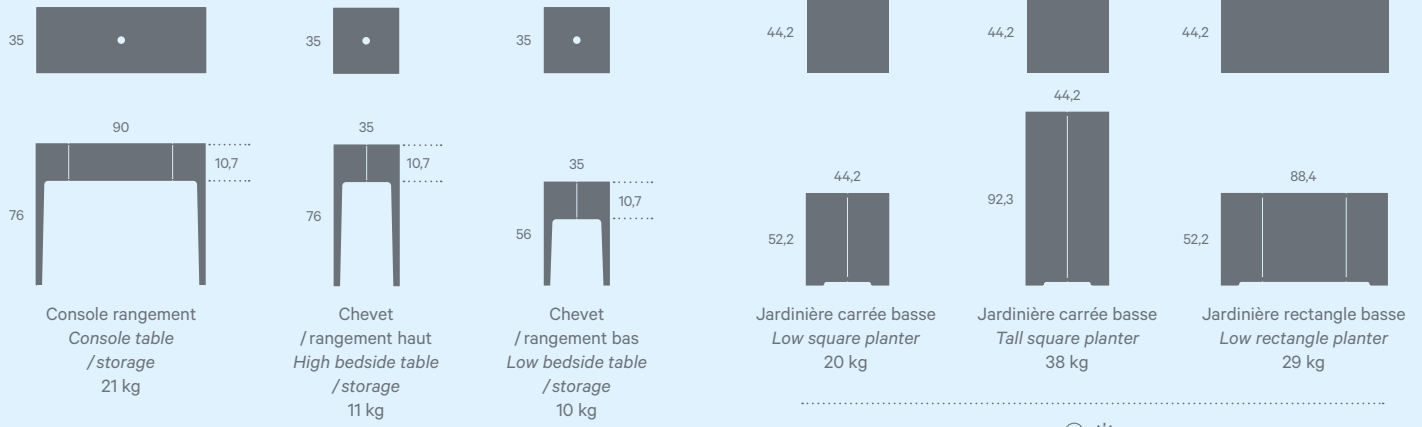

Perçage Ø 4 cm pour passage prise dans le plateau
 Hole for cables 4 cm in the top



Hauteur maximale du pot à positionner dans le bac : 39 cm
 Maximum height of plant pot to use inside the planter 39 cm

Barber

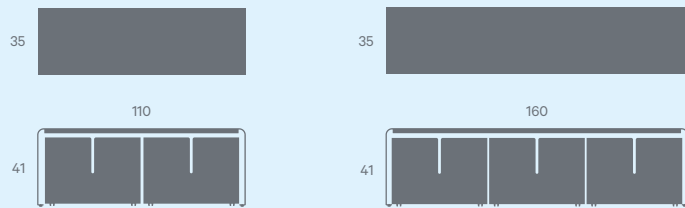

Meuble TV | TV stand
 Deux tiroirs* | Two drawers*
 Un renforts sous plateau
 One horizontal reinforcement
 under the main piece
 45 kg

Meuble TV | TV stand
 Trois tiroirs* | Three drawers*
 Deux renforts sous plateau
 Two horizontal reinforcements
 under the main piece
 60 kg

* Tiroirs montés sur roulettes
 Drawers on wheels

Levant

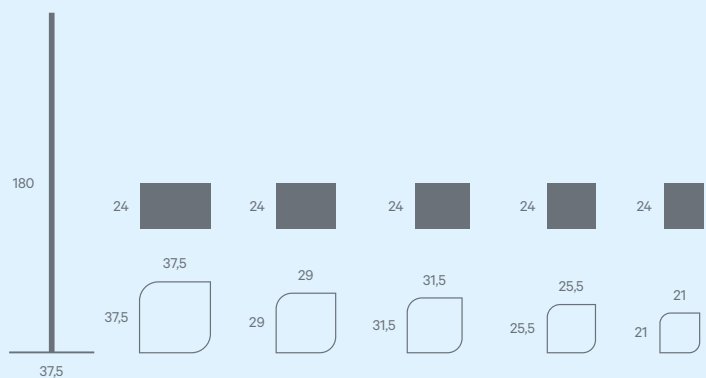

Bibliothèque modulaire | *Modular bookshelf*

Socle et tube | *Base and tube* (AC)

Modules (AL)

51 kg (house icon) (X)

Knick

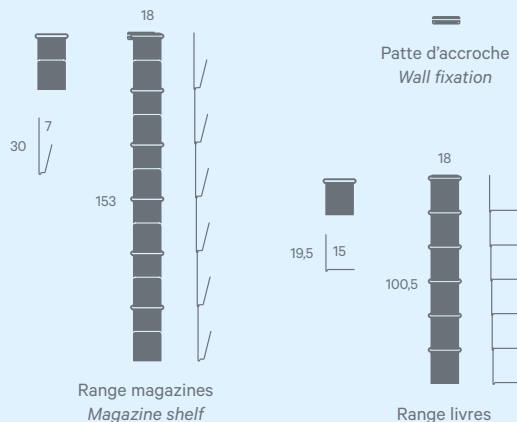

Range magazines
Magazine shelf

Range livres
Book shelf

(AC) 6 kg (house icon) (X)

(poids de six pièces | *weight of six units*)

Alizée



Étagère rail à tiroirs | *Shelf with drawers*

(AC) 12 kg (house icon) (X)

(AC) 11 kg (house icon) (X)



Dos: cinq perforages pour fixation
Back: five openings on the back for wall fixation

Pampero

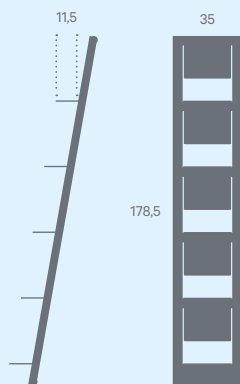

Étagère | *Shelf*

Avec système de blocage
With locking system

(AC) 14 kg (house icon) (X)

Xlokk



Porte-manteau deux pieds à fixer au mur | *Coat rack two legs to be fixed on a wall*

Deux patères rondes | *2 round hooks*
Ø 10,2 / Ø 11,2

Un crochet caché à l'intérieur des pieds
One hook hidden in the legs

(AC) 12 kg (house icon) (X)

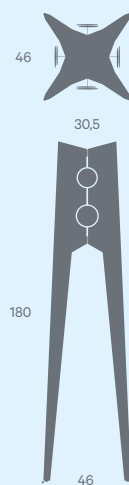

Porte-manteau quatre pieds
Coat rack four legs

Huit patères rondes | *Eight round hooks*
Ø 10,2 / Ø 11,2

Quatre crochets cachés à l'intérieur des pieds | *Four hooks hidden in the legs*

(AC) 20 kg (house icon) (X)

Bôme

Système de rangement modulaire | *Storage system*

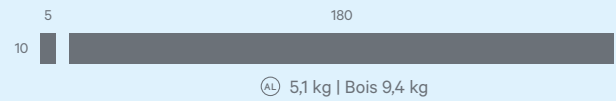
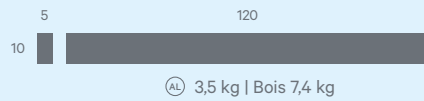
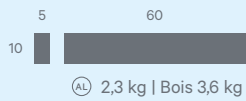

Barres

Aluminium: couleur au choix dans notre gamme
Bois: frêne massif huilé, mat
Supports pour fixation au mur fournis (couleur au choix)

Poles

Aluminium: pick a color
Wood: massive ash, mat oil
Wall brackets provided (pick a color)

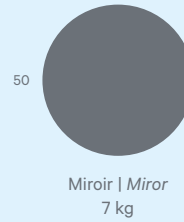
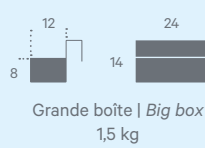
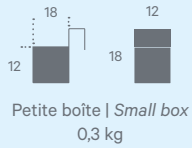
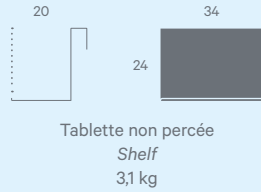
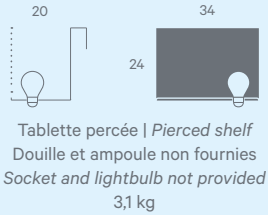

Fragment

Lampe à poser au sol en trois modules
Floor lamp in 3 parts

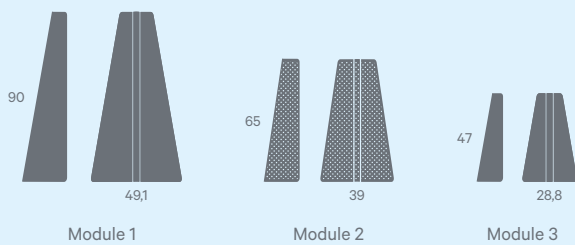

Cordon gris de 2m avec interrupteur fourni
2m grey cable with switch provided
Ampoule E27 non fournie | *E27 light bulb not provided*
AL 12 kg
(poids des trois modules | *weight of the full set*)

Diablo

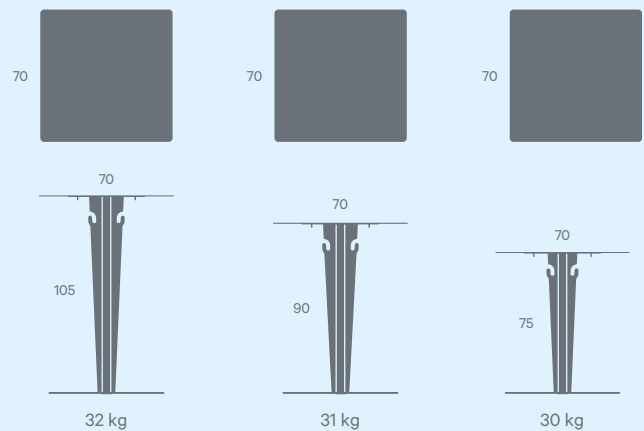
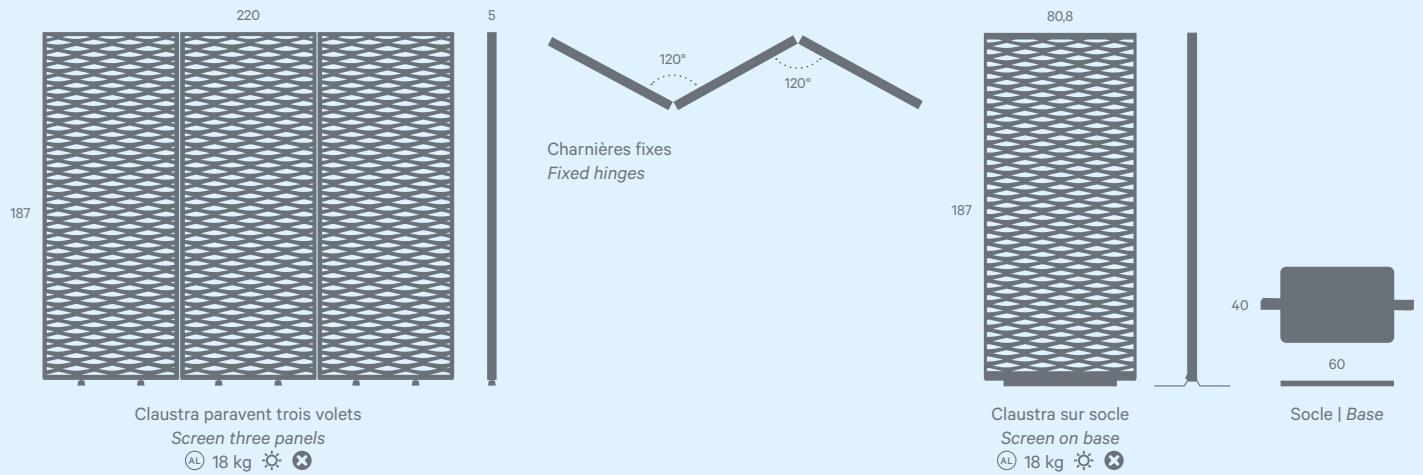
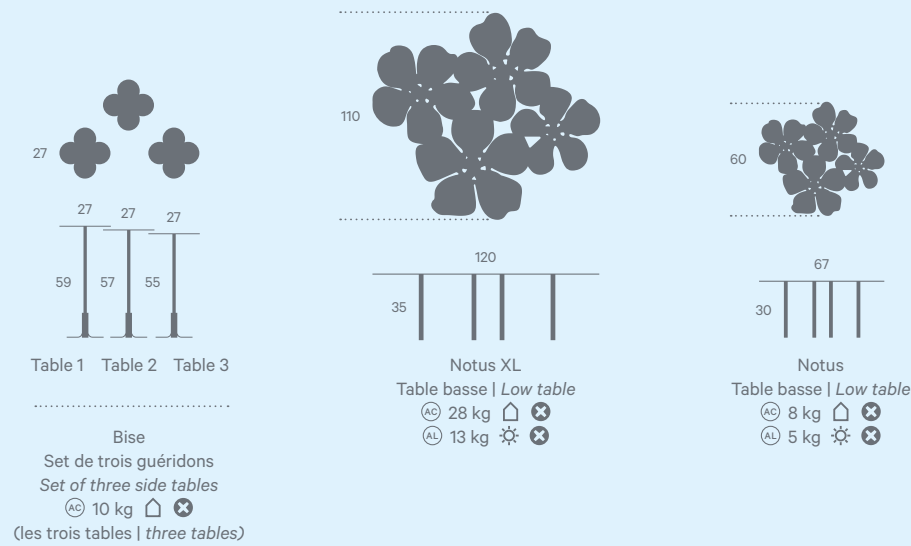

Table porte sac | *Table with hooks*
Option cataphorèse pour usage extérieur sur demande
Cataphoresis treatment for outdoor use, on demand
AL

Mistral



Fleurs | Flowers



Petit mobilier | Small furniture

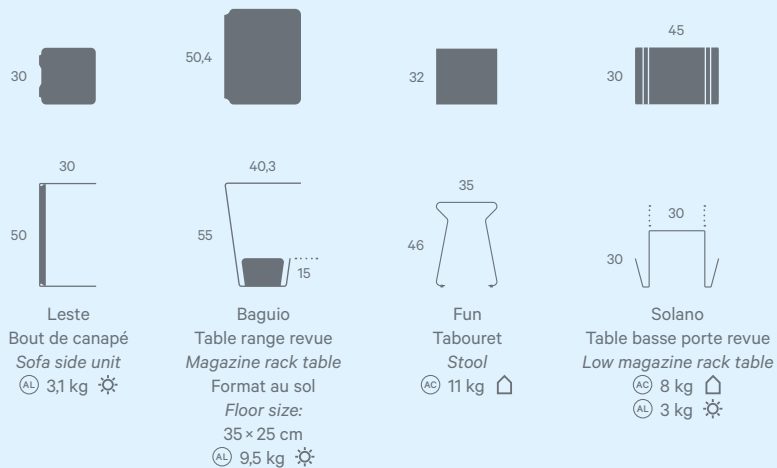

Lueur

Set de trois bougeoirs | Set of three candle holders

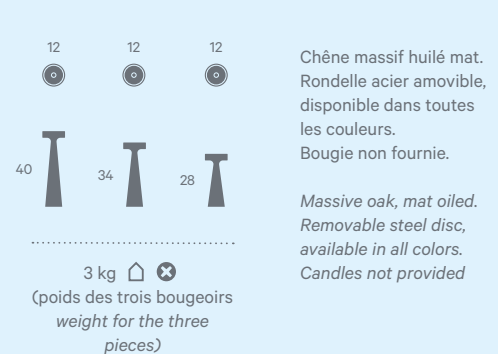

Basics

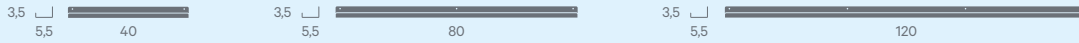

Zip Rails muraux porte tableau | Sledges

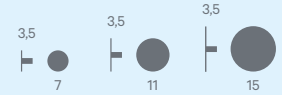
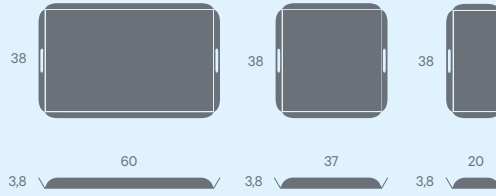
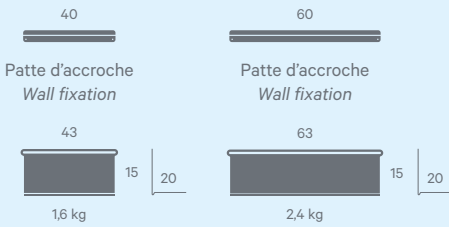

Clap
Patères murales | Hooks

 Existe avec vis pour cheville molly ou vis pour bois
 Exists both with a screw for molly peg and with a screw for wood

Oups
Étagères | Shelves

Crac
Plateaux | Trays

 (poids des trois plateaux | weight for a full set)

Centres de table | Table centerpieces

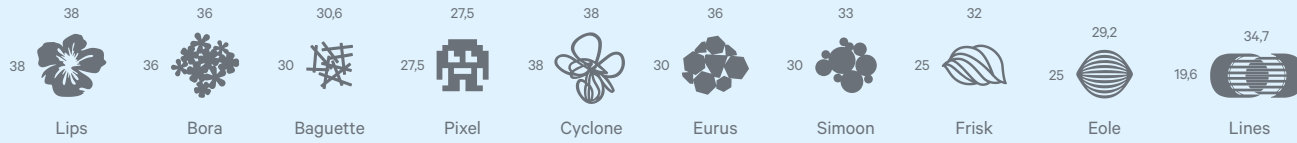

1 kg

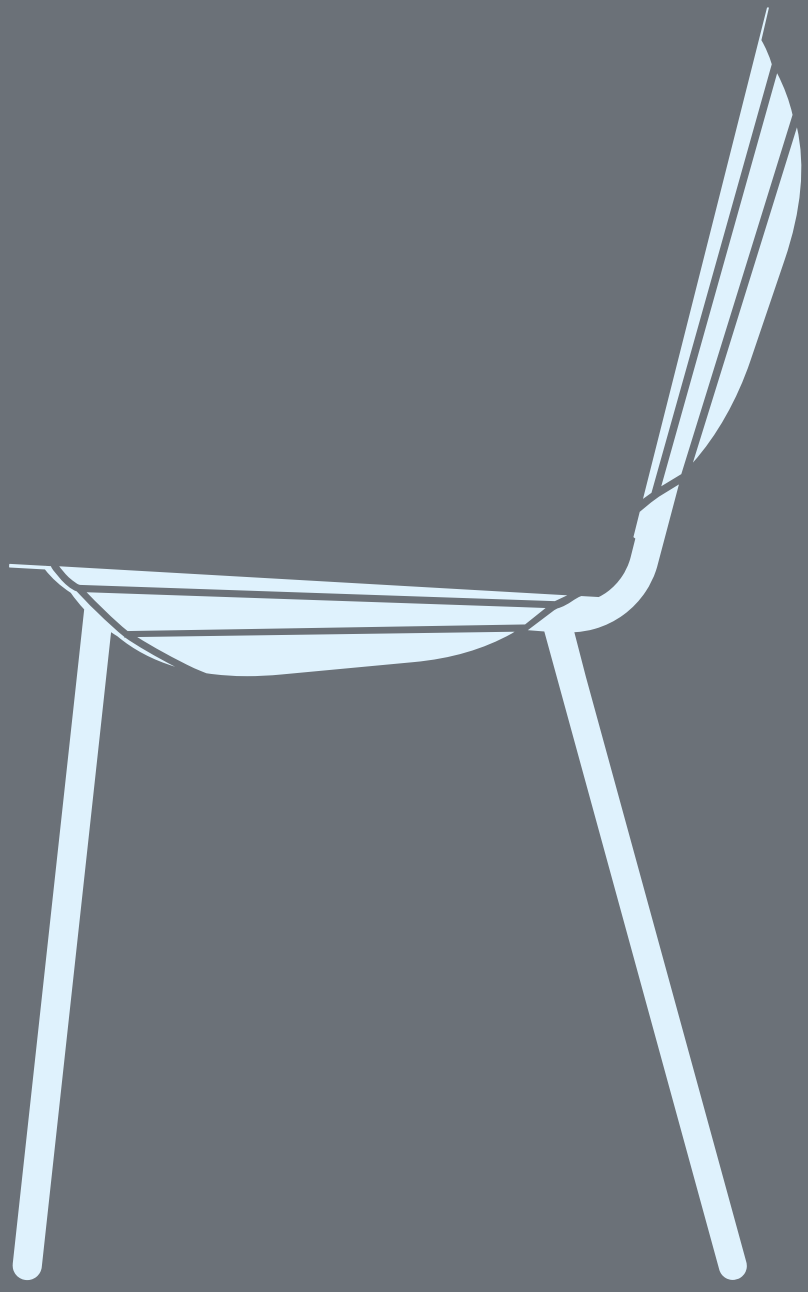

Crédit photos | Photo credit
Pierrick Verny,
Visuels détournés réalisés
par les designers auteurs
des produits | *Cropped images*
realized by the designers
who created the products.

Conception graphique
Graphic design: Trafik

Matiere Grise™
Dessins et modèles déposés.
© Toute reproduction interdite.
Photos, coloris et données
techniques non contractuels.
Drawings and models registred
© Any reproduction forbidden.
Pictures colors and technical
information are not contractual.

Catalogue imprimé en décembre
2018 | *Printed in December 2018*

Liste des revendeurs et fiches
produits sur | *Retailers on*
www.matieregrise-design.com

Contact | Contact
Matière Grise
ZA de Charpenay
172 rue de Charpenay
69210 Lentilly
France

T. +33 (0)4 78 34 95 28
info@matieregrise-design.com

www
. matieregrise
- design . com

