

Gray, Loll, Next, Nuvola Collections



GERVASONI

1882

Gray, Loll,
Next, Nuvola

Collections

Gervasoni 1882





I. Un nuovo modo di concepire l'arredo viene raccontato attraverso un viaggio in luoghi diversi che vuole narrare l'attenta ricerca di Gervasoni nel mostrare i prodotti nei più svariati contesti: da spazi in città, a dimore affacciate sul lago o ad altre immerse nella natura più profonda, per un percorso all'insegna della versatilità e adattabilità.

E. Gervasoni's belief in displaying its products in a variety of contexts finds expression in a whole new way of envisaging furnishing, as a journey to different places: from urban spaces to lakeside residences and dwellings immersed in unspoilt nature, a journey founded on versatility and adaptability.

F. Une nouvelle façon de concevoir le mobilier se raconte au fil des pages de ce catalogue : un voyage vers différents lieux, qui vise à illustrer la recherche attentive de Gervasoni en montrant les produits dans les contextes les plus variés. Des habitats urbains à ceux des bords de lac, en passant par d'autres immergés dans la nature la plus profonde, pour un parcours placé sous le signe de la polyvalence et l'adaptabilité.

D. Eine neue Art, Möbel zu konzipieren, wird über diesen Katalog erzählt: eine Reise an verschiedene Orte, die von der eingehenden Recherche von Gervasoni beim Präsentieren der Produkte in den unterschiedlichsten Kontexten berichten möchte. Von Wohnungen in der Stadt über jene am See bis hin zu solchen mitten in der Natur, für einen Pfad im Zeichen der Vielseitigkeit und Anpassbarkeit.

Houses Index:

1. Royal Colours
009 – 029
2. Grey Duplex
031 – 051
3. Home of
Contrasts
053 – 067
4. Blue Lights
069 – 093
5. Green House
095 – 121
6. Urban Jungle
123 – 151
7. Minimal Villa
153 – 175





1. Royal Colours





↑ Gray 05: Divanetto/ Loveseat in Animals Butterfly-C (stitching 8450 Rosa)
Cushions: 60x60 in Nuage Plum-D (stitching 8000 Scozia),
50x50 in Nuage Fog-D (stitching 8125 Bordeaux), Animals Butterfly-C (stitching 8450 Rosa), 70x70 in Tweed Rice-D (stitching 1050 Panna)



Sweet 98

Log S, M

Gray 05

Guna 03

↑ Loll 07: Poltroncina/ Armchair in Nuage Plum-D (piping Nuage Plum)
↑ Guna 01 Red: Runner ↑ Guna 03 Red: Tappeto/ Carpet



Spin S, M, L

Next 141

Loll Configuration 8

Brick 247, 248

↑ Loll Configuration 08: Divano/ Sofa in Linum Kaki-C (stitching 6300 Tabacco)
↑ Loose cushions: 2 C.Loll PI in Minù Mattone-C (stitching 3475 Salvia), Winds Bora (stitching 8000 Scozia) 4 C.Loll XS in Artist Hopper-C (stitching 6300 Tabacco), Deus Bacco-C (stitching 8000 Scozia), Winds Scirocco-C (stitching 8125 Bordeaux), Bear Polar-D



Next 142, 144

Gray 07

↑ Gray 07: Poltrona/ Armchair in Minù Mattone-C (stitching 3475 Salvia) Cushions: 65x50 in Minù Mattone-C (stitching 3475 Salvia), Linum Kaki-C (stitching 3475 Salvia), 50x50 in Tweed Rye-D (stitching 6300 Tabacco)



Gray 07

↑ Gray 07: Poltrona/ Armchair in Minù Mattone-C (stitching 3475 Salvia)
Cushions: 65x50 in Minù Mattone-C (stitching 3475 Salvia), Linum Kaki-C
(stitching 3475 Salvia), 50x50 in Deus Bacco-C (stitching 8000 Scozia)





Brass 96

Gray 26

Gray 33

Gray 24

↑ Gray 33: Tavolo rettangolare. Gambe in porcellana bianca. Piano in lamiera di ferro cerata/ Rectangular table. Feet in white china. Waxed iron plate top.

↑ Gray 24: Sedia/ Chair. Optional cushion in Birds Crow-C (stitching 6525 Grafite)

↑ Gray 26: Sedia/ Chair in Birds Crow-C (stitching 6525 Grafite)









↑→ Gray 08: Poltroncina/ Armchair in Bear Polar-D



Gray 08



Next 136

↑ Next 136: Tavolo rotondo. Gamba centrale in fusione di alluminio. Piano in noce Canaletto/ Round table. Cast aluminium central base. Natural lacquered American walnut top.



Gray 06

Next 25

↑ Gray 06: Poltrona/ Armchair in Lume Buio-B (stitching 6550 Nero)
Cushions: 70x70 in Lume Luce-B (stitching 1050 Panna)
↑ Next 25: Sedia/ Chair in Jack Grigio-C (stitching 1050 Panna)





Sweet 98

Gray 61

Eco 02

↑ Eco 02 White: Tappeto/ Carpet
↑ Gray 61: Consolle in noce Canaletto/
Consolle in Natural lacquered American walnut top



Brick 18, 19

Brick 241, 242, 244



Gray 04 R

←
Gray 04 R: Dormeuse/
Day-bed in Row Taupe
Verso-C (stitching
6450 Ardesia)
Cushions: 70x70 in
Row Seal Verso-C
(stitching 6450
Ardesia), 60x60 in
Row Taupe Verso-C
(stitching 6450
Ardesia), 50x50 in
Tweed Rye-D (stitching
6450 Ardesia)

←
Gray 04 R: Dormeuse/
Day-bed in Row Seal
Verso-C (stitching
6450 Ardesia)
Cushions: 70x70 in
Row Taupe Verso-C
(stitching 6450
Ardesia), 60x60 in Row
Seal Verso-C (stitching
6450 Ardesia), 50x50
in Tweed Rye-D
(stitching 6450
Ardesia)

←
Brick 18: Pouf/
Ottoman in Tweed
Rye-D (stitching 6450
Ardesia)

←
Brick 19: Pouf/
Ottoman in Row Taupe
Verso-C (stitching
1475 Tortora)



Gray 04 R





Gray 06

Gray 41

↑ Gray 06: Poltrona/ Armchair in Lume Buio-B
(stitching 6550 Nero) Cushions: 70x70 in Lume
Luce-B (stitching 1050 Panna)



2. Grey Duplex





Spin L

Loll 09

Loll 08

↑ Loll 08: Pouf/ Ottoman in Bear Polar-D
↑ Loll 09: Poltrona/ Armchair in Bear Polar-D



Log S, M



Brick L

↑ Gray 29: Dondolo/ Rocking chair. Optional cushion in Minù Stone-C (stitching 6450 Ardesia)



Gray 29

Brick M



↑ Loll 01: Poltrona/ Armchair in Deus Bacco-C
(stitching 8125 Bordeaux)



Spin S, L

Loll 01

Next 147, 148





Gray 39

Gray 23



Loll 12

Gray 49

↑ Loll 12: Divano/ Sofa in Artist Monet–C (stitching 2375 Corteccia)
↑ Loose cushions: 1 C.LOLL PI in Artist Monet –C (stitching 2375 Corteccia)
→ Gray 06: Poltrona/ Armchair in Jack Marrone–C (stitching 6525 Grafite)
Cushion: 70x70 in Artist Monet–C (stitching 6375 Perla)



Loll 14

Gray 42

Gray 06

↑ Loll 14: Divano/ Sofa in Jack Marrone-C (stitching 2375 Corteccia)
↑ Loose cushions: 1 C.Loll Pl in Artist Monet-C (stitching 2375 Corteccia)
1 C.Loll XS in Artist Goya-C (stitching 2375 Corteccia)



↑ Loll 14: Divano/ Sofa in Jack Marrone-C (stitching 2375 Corteccia)
↑ Loose cushions: 1 C.Loll PI in Artist Monet-C (stitching 2375 Corteccia)
→ Nuvola 05: Poltrona/ Armchair in Birds Peacock-C (stitching 5350 Mare)



Nuvola 05

Bolla 13

Bolla 15

→
Next 137: Tavolo
ovale. Gamba
centrale in fusione
di alluminio. Piano
in marmo bianco
Carrara/ Oval table.
Cast aluminium
central base.
White Carrara
marble top.





Next 137

Allu 224



Ghost 23

Gray 38

↑ Ghost 23: Sedia/ Side chair in Artist Monet-C (stitching 6300 Tabacco)
↑ Eco 02 Natural: Tappeto/ Carpet



Sweet 98

Eco 02

↑ Gray 38: Tavolo rotondo. Base in gres porcellanato bianco. Piano a doghe in rovere laccato tortora/ Round table. Central base in white porcelain stoneware. Top in dove-gray lacquered oak slats.



↑ Gray 38: Tavolo rotondo. Base in gres porcellanato bianco.
Piano a doghe in rovere laccato tortora/ Round table.
Central base in white porcelain stoneware. Top in dove-gray lacquered oak slats.
↑ Ghost 23: Sedia/ Side chair in Artist Monet-C (stitching 6300 Tabacco)





Log S, L

Loll 09



3. Home of Contrasts





Guna 03

Loll 09

Loll 08

News 108



Brick 241, 242

Loll 08

↑ Loll Configuration 09/bis: Divano/ Sofa in Birds Seagull-C (stitching 6300 Tabacco)
↑ Loose cushions: 3 C.Loll Pl in Winds Grecale-C (stitching 1050 Panna),
Linum Kaki-C (stitching 3475 Salvia), Linum Mauve-C (stitching 8450 Rosa)
3 C.Loll XS in Winds Scirocco-C (stitching 8450 Rosa), Birds Seagull-C (stitching
1050 Panna), Linum Concrete-C (stitching 6450 Ardesia)



*Bolla S,
M, XL*

Loll Configuration 9/bis

Bolla 12







Loll 29

↑ Loll 29: Pouf/ Ottoman in Animals Pigeon-C (stitching 6525 Grafite)
→ Loose cushion: C.Loll PI in Animals Pigeon-C (stitching 6525 Grafite)



Brass 95

News 108

Brick 241



Gray 51



Gray 23



Gray 51

→ Gray 26: Poltroncina/ Armchair in Tweed Sunrise-D
(stitching 4525 Spritz)



Sweet 98

Gray 50

Gray 26



Sweet 96

Gray 21

Next 136

Next 999

←
Next 136: Tavolo
rotondo. Gamba
centrale in fusione
di alluminio. Piano
di alluminio. Piano
in marmo bianco
Carrara/ Round table.
Cast aluminium
central base. White
Carrara marble top.
→
Next 999: Tappeto/
Carpet - Slate





4. Blue Lights





Brass 45

Loll 16

↑ Loll 16: Divano/ Sofa in Quilt Velour Storm Grey-C (stitching 6475 Antracite)
Lumbar cushions: 100x40 in Jack Marrone-C (stitching 6525 Grafite)



Brass 44

Brick 18, 19

Gray 49

↑ Brick 18: Pouf/ Ottoman in Jack Grigio-C (stitching 6450 Ardesia)
↑ Brick 19: Pouf/ Ottoman in Jack Marrone-C (stitching 6525 Grafite)



Loll 05

↑ Loll 05: Poltrona/ Armchair in Linum Mauve-C (stitching 8450 Rosa)
→ Loll 16: Divano/ Sofa in Quilt Velour Storm Grey-C (stitching 6475 Antracite)
Lumbar cushions: 100x40 in Jack Marrone-C (stitching 6525 Grafite)



Loll 16



↑ Loll Configuration 01: Divano/ Sofa in Artist Monet–C (stitching 6375 Perla)
↑ Loose cushions: 1 C.Loll PI in Winds Scirocco–C (stitching 8450 Rosa)
2 C.Loll XS in Artist Cezanne–C (stitching 6300 Tabacco), Artist Picasso–C (stitching 1450 Nocciola)



Loll Configuration 1

Bolla 15

Brass 45

→
Gray 32: Tavolo
quadrato. Piano
e gambe in rovere
laccato grigio/
Square table.
Top and legs in grey
lacquered oak.







Gray 05

Next 142

Next 148

↑ Gray 05: Divanetto/ Loveseat in Linum Concrete-C (stitching 6450 Ardesia)
Cushions: 70x70 in Tweed Rice-D (stitching 1050 Panna), 60x60 in Tweed Rye-D
(stitching 6450 Ardesia), 50x50 in Nuage Iron-D (stitching 6475 Antracite)
↑ Loll 07: Poltroncina/ Armchair in Bear Polar-D





Gray 05

↑ Gray 05: Divanetto/ Loveseat in Linum Concrete-C (stitching 6450 Ardesia)
Cushions: 70x70 in Tweed Rice-D (stitching 1050 Panna)
60x60 in Tweed Rye-D (stitching 6450 Ardesia), 50x50 in Nuage Iron-D
(stitching 6475 Antracite)



Gray 03

→
Gray 03: Divano/
Sofa in Nuage Fog-D
(stitching 6375 Perla)
Cushions: 115x50 in
Lume Buio-B (stitching
6550 Nero), Lume
Luce-B (stitching 1050
Panna), Lume Ombra-B
(stitching 6450 Ardesia),
Nuage Iron-D (stitching
6475 Antracite), Nuage
Fog-D (stitching 6375
Perla), 65x50 in Lume
Ombra-B (stitching
6450 Ardesia), Nuage
Iron-D (stitching 6475
Antracite)

→
Loll 05: Poltrona/
Armchair in Winds
Scirocco-C (stitching
8450 Rosa)

→
Loll 08: Pouf/ Ottoman
in Lume Luce-B

→
Loll 08: Pouf/ Ottoman
in Lume Ombra-B



Loll 08



Gray 03

Brick S, M

Loll 05





Loll 07

Next 148



Gray 33

Next 25

↑ Gray 33: Tavolo rettangolare. Piano e gambe in noce Canaletto/
Rectangular table. Top and legs in natural lacquered American walnut.
↑ Next 25: Sedia/ Chair in Birds Seagull-C (stitching 6300 Tabacco)





↑ Gray 33: Tavolo rettangolare. Gambe in fusione di alluminio lucidato.
Piano in noce Canaletto/ Rectangular table. Legs in cast polished aluminum.
Top in natural lacquered American walnut.

↑ Next 25: Sedia/ Chair in Birds Seagull-C (stitching 6300 Tabacco)



→
Nuvola 12: Divano/
Sofa in 3D Grafite-E
(stitching 6525
Grafite)

→
Gray 07: Poltrona/
Armchair in Trama
Ginepro-C (stitching
6525 Grafite)
Cushions: 65x50 in
Trama Ginepro-C
(stitching 6525
Grafite), Trama
Vaniglia-C (stitching
1050 Panna)
50x50 in Trama
Anice-C (stitching
6475 Antracite)

→
Brick 18: Pouf/
Ottoman in Nuage
Saffron-D (stitching
8000 Scozia)

→
Brick 19: Pouf/
Ottoman in Nuage
Plum-D (stitching
8000 Scozia)



Log S, L

Gray 07



Nuvola 12

Brick 18, 19



- ← Nuvola 12: Divano/ Sofa in 3D Grafite-E (stitching 6525 Grafite)
- ← Brick 18: Pouf/ Ottoman in Nuage Saffron-D (stitching 8000 Scozia)
- ← Brick 19: Pouf/ Ottoman in Nuage Plum-D (stitching 8000 Scozia)



5. Green House





Corallo

Nuvola 05

Next 998

Brick M

↑ Nuvola 05: Poltrona/ Armchair in Bear Polar-D
↑ Next 998: Runner - Brown



Gray 61

→
Loll Configuration 10:
Divano/ Sofa
in Tweed Barley-D
(stitching 6450
Ardesia)

→
Loose cushions:
3 C.Loll PI in Nuage
Sun-D (stitching 3225
Verde), Artist Cezanne
-C (stitching 6300
Tabacco), Tweed
Rye-D (stitching 6450
Ardesia)
3 C.Loll XS in Linum
Concrete-C (stitching
6450 Ardesia), Winds
Bora-C (stitching
6300 Tabacco),
Winds Ostro-C
(stitching 3225 Verde)

→
Loll 07: Poltroncina/
Armchair in Winds
Bora-C (piping Winds
Bora)





Gray 46

Loll Configuration 10

→ Loll Configuration 10: Divano/ Sofa in Tweed Barley-D (stitching 6450 Ardesia)
Loose cushions: 1 C.Loll PI in Nuage Sun-D (stitching 3225 Verde), 3 C.Loll XS
in Winds Bora-C (stitching 6300 Tabacco), Linum Concrete-C (stitching 6450
Ardesia), Winds Ostro-C (stitching 3225 Verde)
→ Loll 07: Poltroncina/ Armchair in Winds Bora-C (piping Winds Bora)





- ↑ Gray 33: Tavolo rettangolare. Piano e gambe in marmo bianco Carrara/
Rectangular table. Top and legs in white Carrara marble.
- ↑ Ghost 23: Sedia/ Side chair in Deus Pegaso–C (stitching 6375 Perla)
- ↑ Ghost 23: Sedia/ Side chair in Tweed Rye–D (stitching 6450 Ardesia)



Brass 95

Gray 33

Ghost 23



↑ Gray 33: Tavolo rettangolare. Piano e gambe in marmo bianco Carrara/
Rectangular table. Top and legs in white Carrara marble.
→ Ghost 23: Sedia/ Side chair in Tweed Rye-D (stitching 6450 Ardesia)



- Loll 12: Divano/
Sofa in Natural Lino
Bianco-B (stitching
1000 White)
- Loll 28: Pouf/
Ottoman in Natural
Lino Bianco -B
(stitching 1000
White)
- Loll 05: Poltrona/
Armchair in Natural
Lino Bianco-B
(stitching 1475
Tortora)



Brick M

Loll 28



Loll 12

Inout 44

Brick L

Loll 05

Gray 42



Loll 12

Inout 44

↑ Loll 12: Divano/ Sofa in Natural Lino Bianco-B (stitching 1000 White)
↑ Loose cushions: 1 C.Loll PI in Nuage Sun-D (stitching 3225 Verde)
2 C.Loll XS in Winds Ostro-C (stitching 3225 Verde), Winds Bora-C (stitching 6300 Tabacco)



Loll 28

↑ Loll 28: Pouf/ Ottoman in Natural Lino Bianco-B
(stitching 1000 White)



Loll 05

↑ Loll 05: Poltrona/ Armchair in Natural Lino Bianco-B
(stitching 1475 Tortora)





↑ Next 236: Tavolo rotondo. Base centrale in cemento finitura crackle. Piano in marmo bianco Carrara/ Round table. Central concrete base, crackle finish. Top in white Carrara marble.



Sweet 95

Next 236

Gray 23

Gray 21

↑ Gray 21: Sedia/ Chair. Optional cushion in Tweed Sunrise-D (stitching 6375 Perla)
↑ Gray 23: Sedia/ Chair. Optional cushion in Tweed Sunrise-D (stitching 6375 Perla)



Gray 38

↑ Gray 38: Tavolo rotondo. Base centrale in gres porcellanato bianco. Piano in marmo bianco Carrara/ Round table. Central base in white porcelain stoneware. Top in white Carrara marble.
↑ Gray 22: Sedia/ Chair in Tweed Barley-D. Optional cushion in Tweed Barley-D (stitching 6375 Perla)



Gray 22

Gray 61



↑ Loll 80: Letto/ Bed in Winds Bora-C (stitching 6300 Tabacco)
↑ Loll 08: Pouf/ Ottoman in Bear Polar-D



Loll 08

LC 198

Loll 80



Gray 45



Sweet 91

Loll 09

Loll 08

Gray 42

- ↑ Loll 08: Pouf/ Ottoman in Bear Polar-D
- ↑ Loll 09: Poltrona/ Armchair in Bear Polar-D
- Loll 07: Poltroncina/ Armchair in Winds Bora-C (piping Winds Bora)





6. Urban Jungle





Gray 01

Gray 42

Brick 18

- ↑ Gray 01: Poltrona/ Armchair in Malta 3 Rena-C (stitching 1225 Corda)
Cushions: 115x50 in Malta 3 Rena-C (stitching 1225 Corda), Malta 3 Piombo-C
(stitching 6300 Tabacco), 65x50 in Atmosfera Brezza-C (stitching 1450 Nocciola)
- ↑ Brick 18: Pouf/ Ottoman in Trama Cannella-C (stitching 6300 Tabacco)
- ↑ Brick 19: Pouf/ Ottoman in Trama Vaniglia-C (stitching 1050 Panna)



Gray 42

Gray 03

Brick 19

Gray 44

↑ Gray 03: Divano/ Sofa in Malta 3 Rena-C (stitching 1225 Corda)
Cushions: 115x50 in Malta 3 Rena-C (stitching 1225 Corda), Malta 3
Piombo-C (stitching 6300 Tabacco), 65x50 in Atmosfera Brezza-C
(stitching 1450 Nocciola)

→
Loll 20 L-R: Chaise
longue/ Day-bed in
Linum Concrete-C
(stitching 6450
Ardesia)





Sweet 97

Loll 20 L-R

Next 148



→ Loll 20 L-R: Chaise longue/ Day-bed in Linum
Concrete-C (stitching 6450 Ardesia)
→ Loose cushion: C.Loll PI in Row Midnight Verso-C
(stitching 6000 Denim)





Sweet 97

Loll Configuration 11

Next 144

↑ Loll Configuration 11: Divano/ Sofa in Deus Tritone-C (stitching 5350 Mare)
↑ Loose cushions: 3 C.Loll PI in Row Seal Verso-C (stitching 5350 Mare), Row Midnight Verso-C (stitching 6000 Denim), Deus Bacco-C (stitching 5350 Mare), 2 C.Loll XS in Artist Renoir-C (stitching 8450 Rosa), Artist Rembrandt-C (stitching 8450 Rosa)



Next 147, 148

Bolla M,S



↑ Loll configuration 11: Divano/ Sofa in Deus Tritone-C (stitching 5350 Mare)
↑ Loose cushions: 2 C.Loll PI in Row Seal Verso-C (stitching 5350 Mare),
Deus Bacco-C (stitching 5350 Mare), 2 C.Loll XS in Artist Rembrandt-C (stitching 8450
Rosa), Artist Renoir-C (stitching 8450 Rosa)





↑ Gray 38: Tavolo rotondo. Base centrale in gres porcellanato bianco.
Piano a doghe di rovere laccato oceano/ Round table.
Central base in white porcelain stoneware. Top in ocean lacquered oak slats.
↑ Gray 22: Sedia/ Chair in Animals Snake-C ↑ Guna 03 Blue: Tappeto/ Carpet



Brass 96

Gray 38

Gray 22

Guna 03

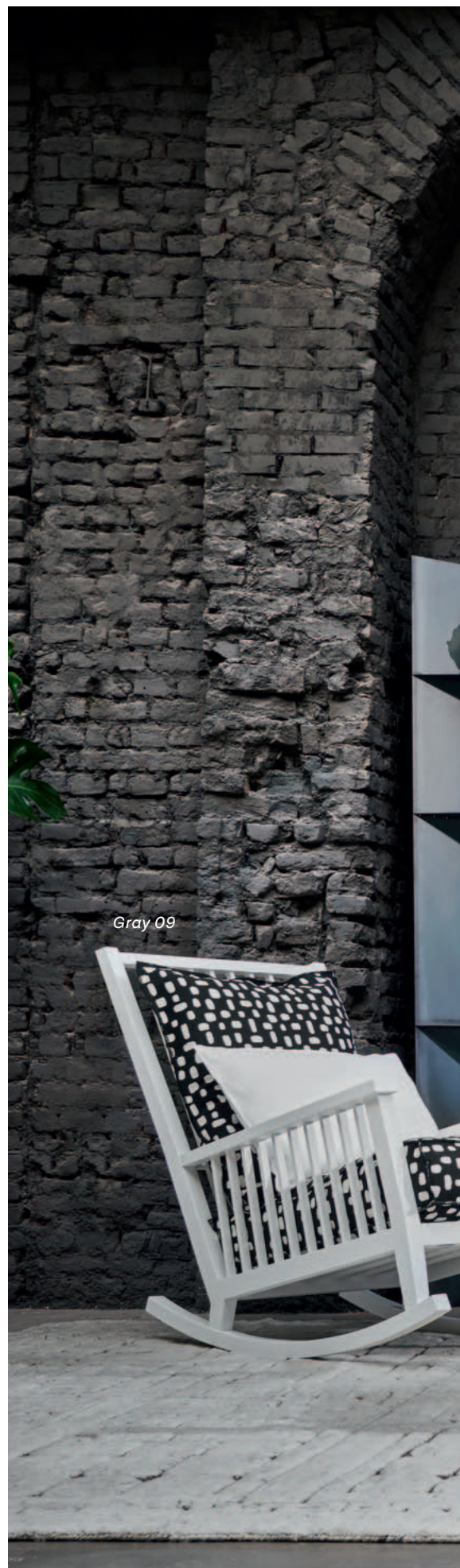

→ Gray 09: Dondolo/ Rocking-chair in Atmosfera Tempesta-C (stitching 6550 Nero). Cushions: 65x50 in Structures Calcare-C (stitching 1000 White), 65x80 in Atmosfera Tempesta-C (stitching 6550 Nero)





Ghost 23

Gray 24

↑ Gray 33: Tavolo rettangolare. Piano e gambe rovere laccato tortora/
Rectangular table. Top and legs in dove-grey lacquered oak.
↑ Ghost 23: Sedia/ Chair in Winds Scirocco-C (stitching 8450 Rosa)



Gray 33





↑ Gray 33: Tavolo rettangolare. Gambe in porcellana bianca.
Piano a doghe di rovere laccato tortora/ Rectangular table.
Legs in white china. Top in dove-grey lacquered oak slats.
↑ Ghost 23: Sedia/ Chair in Winds Scirocco-C (stitching 8450 Rosa)



Nuvola 05

Brass 43

- ← Loll 80 G: Letto/
Bed in Artist Goya-C
(stitching 8000
Scozia)
- ←
- ← Gray 15: Panchetta/
Bench in Artist
Renoir-C (stitching
6475 Antracite)
- ←
- ← Nuvola 05: Poltrona/
Armchair in Deus
Pegaso (stitching
8000 Scozia)

Spin 95

Loll 80 G

Gray 15



- ↑ Nuvola 05: Poltrona/ Armchair in Deus Pegaso-C (stitching 8000 Scozia)
- Loll 80 G: Letto/ Bed in Artist Goya-C (stitching 8000 Scozia)
- Gray 15: Panchetta/ Bench in Artist Renoir-C (stitching 6475 Antracite)





Spin 96

Up 23

Brass 44







Sweet 27

Inout 46 IN



Brass 96

Inout 46 IN

Loll 07



7. Minimal Villa





Nuvola 12

↑ Nuvola 12: Divano/ Sofa in Tweed Rye-D (stitching 6300 Tabacco)
↑ Nuvola 12: Divano/ Sofa in Tweed Barley-D (stitching 6300 Tabacco)



Brass 96

Brass 96

Brass 95

Gray 46

Brass 44, 45



Gray 44

Gray 42

Next 999



Nuvola 09

Gray 46

- ←
Nuvola 09:
Poltrona/ Armchair
in Quilt Malta
Ardesia-D (stitching
6450 Ardesia)
- ←
Next 999: Tappeto/
Carpet-Silver
- ←
Next 999: Tappeto/
Carpet-Slate





← Nuvola 09: Poltrona/ Armchair in Quilt Malta Ardesia-D (stitching 6450 Ardesia)



Loll Configuration 3

Brick 247, 248

- ↑ Loll Configuration 3: Divano/ Sofa in Deus Pegaso-C (stitching 6375 Perla)
- ↑ Loose cushions: 2 C.Loll PI in Deus Pegaso-C (stitching 6375 Perla), Deus Tritone-C (stitching 5350 Mare), 1 C.Loll XS in Row Midnight Verso-C (stitching 6000 Denim)
- ↑ Loll 28: Pouf/ Ottoman in Deus Tritone-C (stitching 5350 Mare)



Brick 241, 242

Loll 28



Loll 28



←
Loll 28: Pouf/
Ottoman in Deus
Tritone-C
(stitching 5350 Mare)





Brick 223

Brass 46



Sweet 91

Brick 221

Next 137

↑ Next 137: Tavolo ovale. Gamba centrale in fusione di alluminio.
Piano in noce Canaletto laccato grigio/ Oval table.
Cast aluminium central base. Grey lacquered American walnut top.



↑ Brick 221: Sedia/ Chair in Trama Anice-C (stitching 6475 Antracite)
↑ Brick 221: Sedia/ Chair in Trama Vaniglia-C (stitching 1050 Panna)

→
Double: Letto/
Bed in Birds Heron-C
(stitching 6450
Ardesia)
→
Gray 15: Panchetta/
Bench in Birds Dove-C
(stitching 6450
Ardesia)
→
Gray 29: Dondolo/
Rocking-chair.
Optional cushion
in Birds Heron-C
(stitching 6450
Ardesia)
→
Next 999: Tappeto/
Carpet - Blue

LC 91

Gray 45

Gray 15



Double

Brick M

LC 97

Gray 29

Next 999



LC 97



Gray 29



Gray 04 R

Brick S

→ Gray 04 L-R: Dormeuse/ Day-bed in Linum Butter-C (stitching 6375 Perla)
Cushions: 70x70 in Winds Bora-C (stitching 6300 Tabacco), 60x60 in Winds
Grecale-C (stitching 1050 Panna), 50x50 in Winds Bora-C (stitching 6300 Tabacco)







Log S, M, L

Sweet 27



Technicals by Collection

↳ Bell, Bolla, Corallo, Spin

I. Grazie alla sua duttilità, il midollino ha permesso di reinterpretare una serie di complementi d'arredo: lampade, attaccapanni e tavolini realizzati in midollino intrecciato a mano. La bellezza dell'intreccio in fibra naturale unita ad un design originale dà vita ad una collezione ideale per completare l'arredo di ogni ambiente della casa, conferendogli carattere e unicità.

E. Thanks to its flexibility, wicker has brought about the reinterpretation of a series of furnishing accessories: lamps, coat hangers and tables made of hand-woven wicker. The beauty of the natural fibre weave combined with an original design breathes life into a collection that is ideal for completing the décor of any room in the house, giving it character and uniqueness.

F. Grâce à sa ductilité, l'osier a permis de réinterpréter une série d'articles d'ameublement : lampes, porte-manteaux et tables basses en osier tressé à la main. La beauté du tissage en fibres naturelles associée à un design original donne vie à une collection idéale pour compléter l'ameublement de n'importe quel espace de la maison, en lui conférant caractère et unicité.

D. Dank seiner Anpassungsfähigkeit hat das Peddigrohr zu einer Neuinterpretation mehrerer Einrichtungsgegenstände geführt: Lampen, Kleiderständer und Beistelltische aus von Hand geflochtenem Peddigrohr. Die Schönheit von geflochtenen Naturfasern in einem originellen Design haucht einer Kollektion Leben ein, die ideal ist, um jeden Raum im Haus auszustatten und ihm einen einzigartigen Charakter zu verleihen.

Finitura Midollino / Wicker Finishes



Bell 95 → P. 114, 115

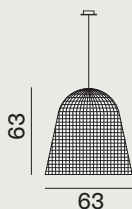

Bolla 10



Bolla 12 → P. 057



Bolla 13 → P. 043



Bolla 15 → P. 043, 075

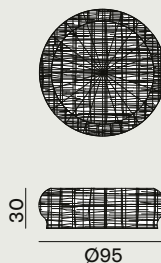

Bolla S → P. 056-057, 059, 130, 131



Bolla M → P. 056-057, 059, 130, 131



Bolla L



Bolla XL → P. 056-057



↳ Bell, Bolla, Corallo, Spin

Corallo → P. 094

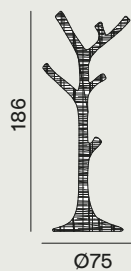

Spin 95 → P. 142-143

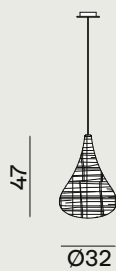

Spin 96 → P. 146

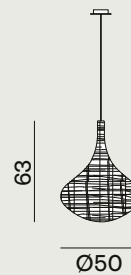

Spin S → P. 012-013, 037

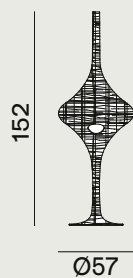

Spin M → P. 012-013, 032

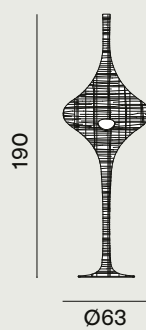

Spin L → P. 012-013, 032, 037

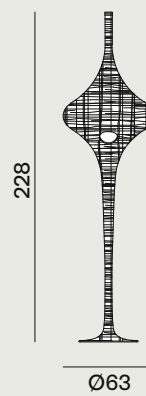

↳ Brass, Silver

I. Dal forte impatto decorativo, le collezioni Brass e Silver uniscono la duttilità dell'ottone alla sua capacità di impreziosire ogni interno grazie ai suoi riflessi luminosi. Le lampade a sospensione hanno una forma leggera di grande appeal visivo: un leggero disco di ottone che fluttua nell'aria riflettendo la luce in maniera poetica e suggestiva. Completano la collezione anche una serie di piccoli tavoli e tavolini dall'immagine scultorea e con il piano in versione ottone o alluminio, per riflessi caldi e dorati o freddi e argentei.

E. With a strong decorative impact, the Brass and Silver collections combine the ductility of brass with its ability to embellish any interior thanks to its luminous reflections. The pendant lamps have a light shape of great visual appeal: a light brass disk that floats in the air reflecting the light in a poetic and suggestive way. The collection is also completed by a series of small tables and coffee tables with a sculptural image and with the top in brass or aluminium, for warm and golden or cold and silver reflections.

F. Avec leur fort impact décoratif, les collections Brass et Silver allient la ductilité du laiton à sa capacité à embellir n'importe quel intérieur grâce à ses reflets lumineux. Les lampes à suspension présentent une forme légère au grand attrait visuel : un disque en laiton léger qui flotte dans l'air et reflète la lumière de manière poétique et suggestive. La collection est également complétée par une série de petites tables et de guéridons à l'image sculpturale et arborant un plateau en version laiton ou aluminium, pour des reflets chauds et dorés ou froids et argentés.

D. Die sehr dekorativen Kollektionen Brass und Silver verbinden die Anpassungsfähigkeit von Messing mit seiner Fähigkeit, alle Innenräume mit Lichtreflexen zu verschönern. Die Hängelampen haben eine leichte Form mit großem visuellen Charme: eine leichte Messingscheibe schwebt in der Luft und reflektiert das Licht auf poetische und stimmungsvolle Art. Die Kollektion wird von ein paar kleinen Tischen und Beistelltischen in Skulptur-Optik mit Tischfläche aus Messing oder Aluminium für warm-goldene bzw. kalt-silberne Reflexe vervollständigt.

Finiture Piano / Top Finishes



Fusione Alluminio
Cast Aluminium

Ottone
Brass

Finiture Lampade / Lamp Finishes

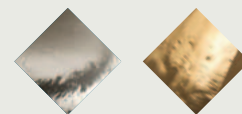

Ottone Nichelato
Nickel-Plated Brass

Ottone Opaco
Matt Brass

Brass 43 → P. 142-143

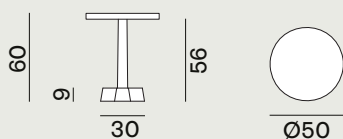

Brass 44 → P. 071, 146, 155

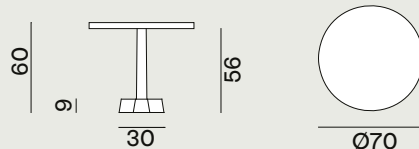

Brass 45 → 070, 155

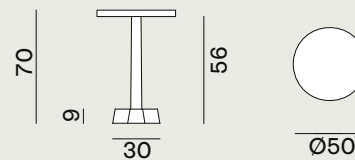

Brass 46 → P. 165

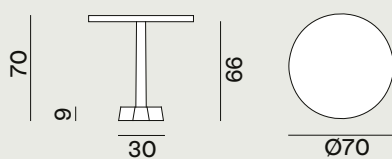

Brass 95 → 061, 102-103, 155

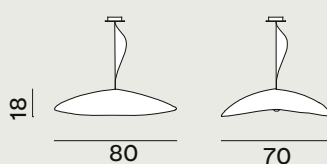

Brass 96 → 016-017, 135, 151, 155

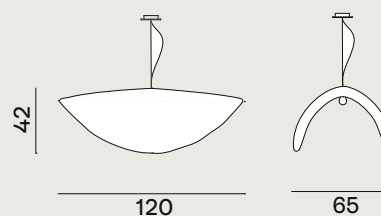

Silver 95 → P. 086-087, 098, 101

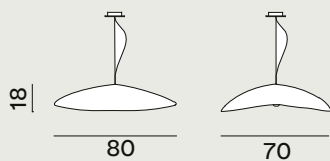

Silver 96 → 074, 098, 101

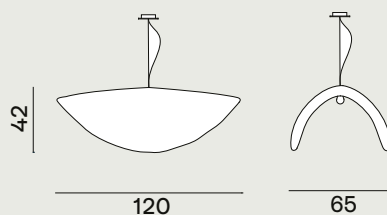

↳ Gray

I. Animo vintage e design contemporaneo caratterizzano Gray, un'articolata collezione di sedie, poltrone, divani, tavoli e tavolini che mescola l'eleganza austera degli arredi classici alla semplicità delle forme nordiche. Una collezione in legno massello di noce o rovere impreziosito da lavorazioni e sagomature e da materiali inusuali come pietra, porcellana, alluminio e marmo.

E. Vintage soul and contemporary design characterise Gray, an articulated collection of chairs, armchairs, sofas, tables and coffee tables that combines the austere elegance of classic furnishings with the simplicity of Nordic forms. A collection in solid walnut or oak embellished with workmanship, shapes and unusual materials, such as stone, porcelain, aluminium and marble.

F. Gray se caractérise par son âme vintage et son design contemporain : une collection articulée, composée de chaises, de fauteuils, de canapés, de tables et de tables basses qui mélange l'élégance rigide du mobilier classique avec la simplicité des formes nordiques. Une collection réalisée en noyer ou en chêne massif, ornée de finitions et de formes et de matériaux originaux, tels que la pierre, la porcelaine, l'aluminium et le marbre.

D. Eine Vintage-Seele und ein modernes Design kennzeichnen Gray, eine ausgefeilte Kollektion von Stühlen, Sesseln, Sofas, Tischen und Beistelltischen, welche die schmucklose Eleganz klassischer Möbel mit der Schlichtheit nordischer Formen verbindet. Eine Kollektion aus massivem Nussbaum oder Eiche, veredelt durch sorgfältige Verarbeitung und Formgebung sowie durch unübliche Materialien wie Stein, Porzellan, Aluminium und Marmor.

Finiture Legno / Wood Finishes

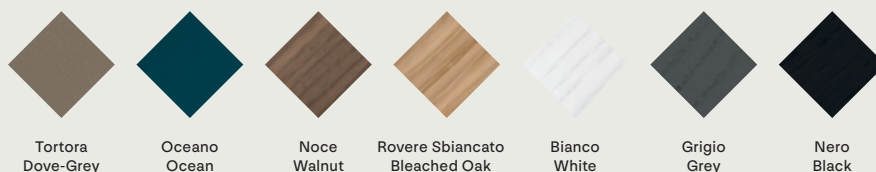

Gray 01 → P. 124

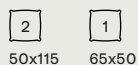
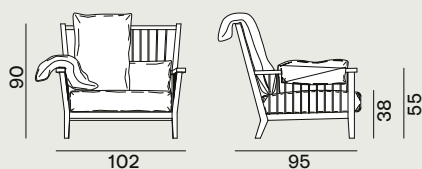

Gray 03 → P. 082-083, 124-125

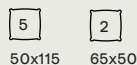
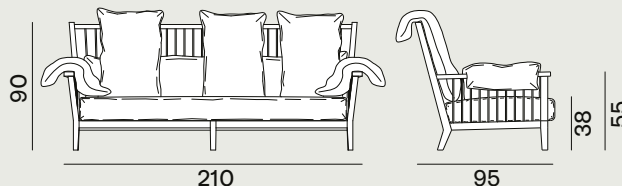

Gray 04 L-R → P. 026-027, 173

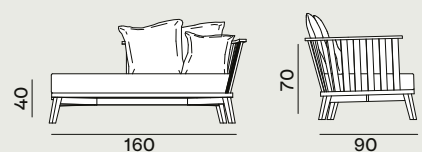

Gray 05 → P. 010-011, 078

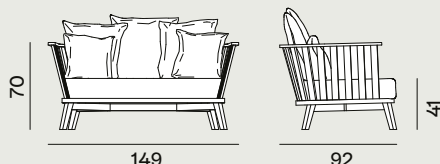

Gray 06 → P. 023, 029, 041

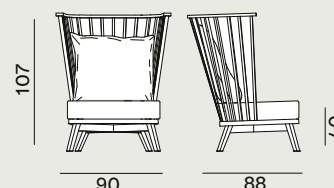

Gray 07 → P. 013-014, 90

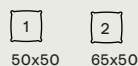
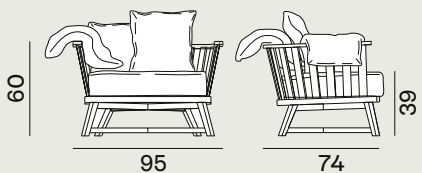

Gray 08 → P. 021

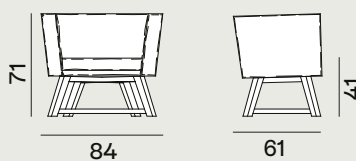

Gray 09 → P. 136-137

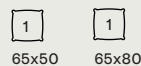
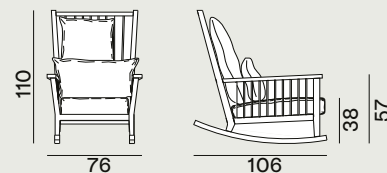

↳ Gray

Gray 15 → P. 142-143, 168-169, 172

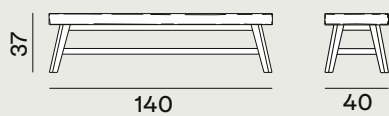

Gray 21 → P. 066, 113

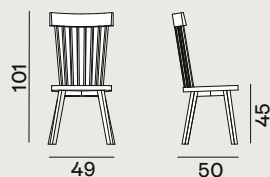

Gray 22 → P. 114-115, 134-135

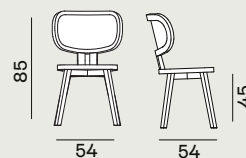

1
Optional

1
Optional

Gray 23 → P. 039, 062, 087, 112

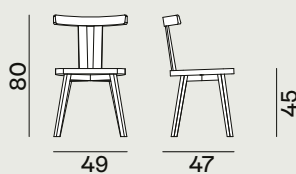

Gray 24 → P. 016, 138-139

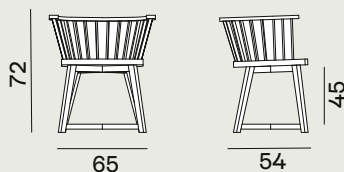

Gray 26/27 → P. 016, 018, 065

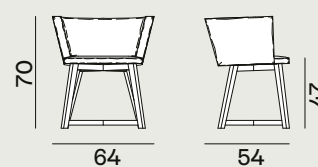

1
Optional

1
Optional

Gray 29 → P. 035, 169, 171

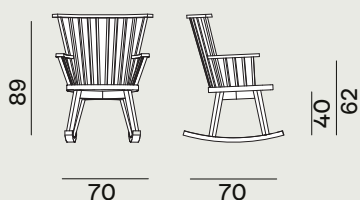

Gray 39 → P. 039

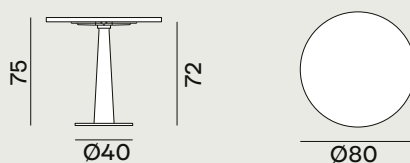

Gray 41 → P. 029

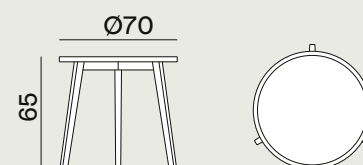

1
Optional

Gray 42 → P. 040-041, 107, 124-125, 156

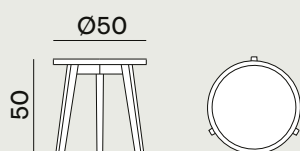

Gray 44 → P. 124-125, 156

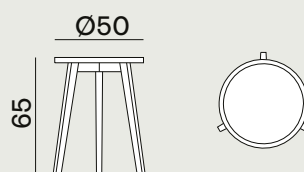

Gray 45 → P. 118, 168

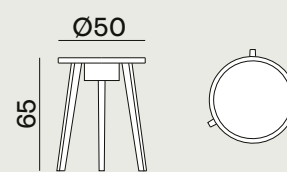

Con cassetto sottopiano
/ With drawer

Gray 46 → P. 099, 154-155

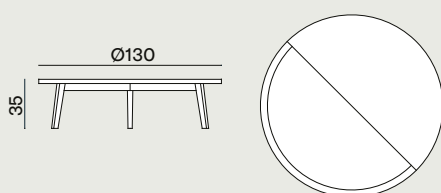

Gray 49 → P. 040-041, 070-071

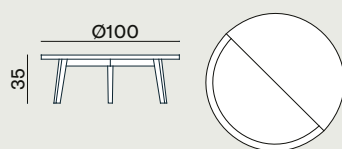

Gray 50 → P. 065

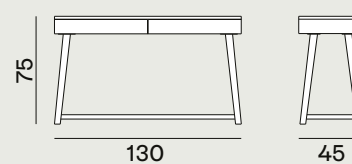

Piano massello
/ Solid top

Piano massello
/ Solid top

↳ Gray

Gray 51 → P. 062, 064

Gray 61 → P. 025, 097

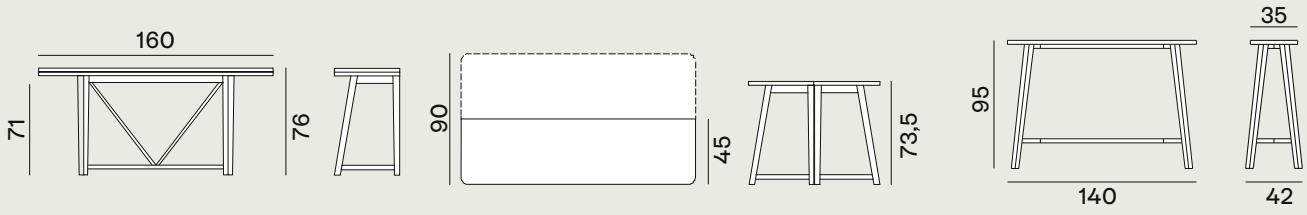

C. Gray S

C. Gray M

C. Gray L

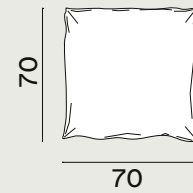
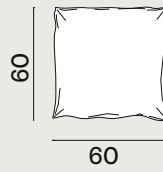
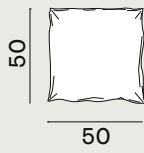

C. Gray PI

C. Gray GR

C. Gray XL

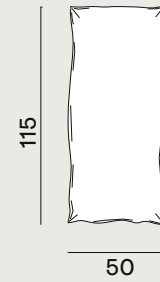
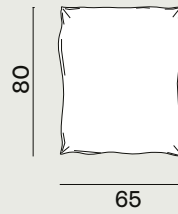
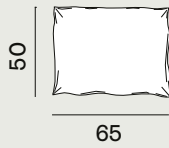

↳ Gray Tables

Finiture Top / Top Finishes



Legno
Wood

Lamiera di Ferro
Waxed Iron Plate

Marmo Bianco
White Marble

Finiture Gambe / Legs Finishes

→ Gray 32, 33, 34, 35

→ Gray 38



Legno
Wood



Alluminio
Aluminium



Marmo Bianco
White Marble



Porcellana Bianca
White China



Gress Porcellanato Bianco
White Porcelain
Stoneware

Finiture Legno / Wood Finishes

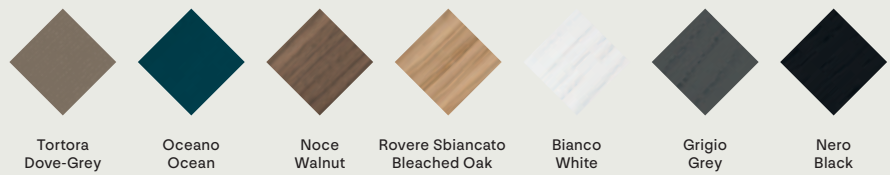

Tortora
Dove-Grey

Oceano
Ocean

Noce
Walnut

Rovere Sbiancato
Bleached Oak

Bianco
White

Grigio
Grey

Nero
Black

Gray 32 → P. 077

Gray 33 → P. 016-017, 086-087, 088, 102-103, 138-139, 140

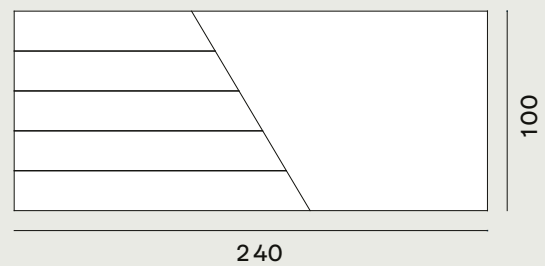
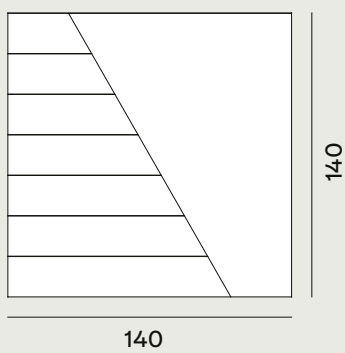
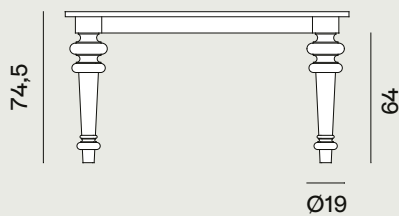

Legno doghe da 20 cm
/ 20 cm wooden slats

Legno doghe da 20 cm
/ 20 cm wooden slats

↳ Gray Tables

Gray 34

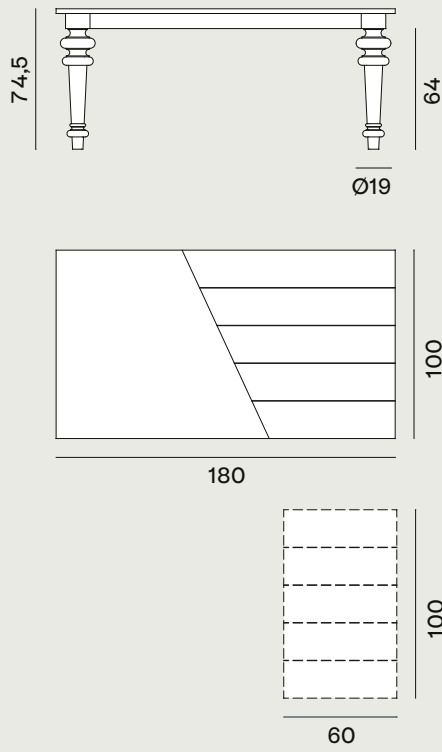

Legno doghe da 20 cm
/ 20 cm wooden slats

Gray 35

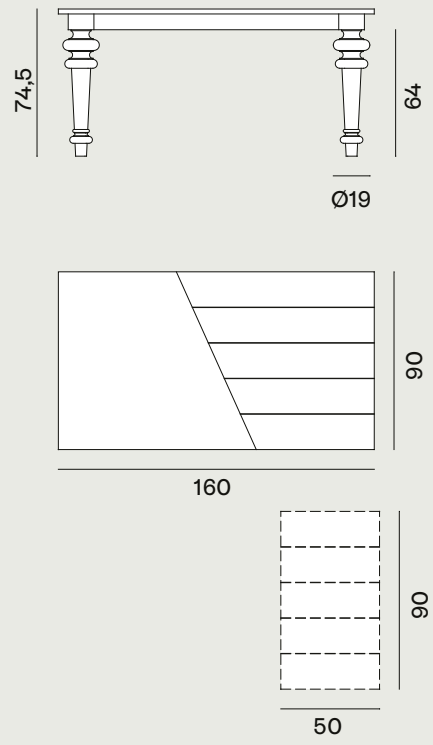

Legno doghe da 20 cm
/ 20 cm wooden slats

Gray 38 → [P. 046-047, 114-115, 135](#)

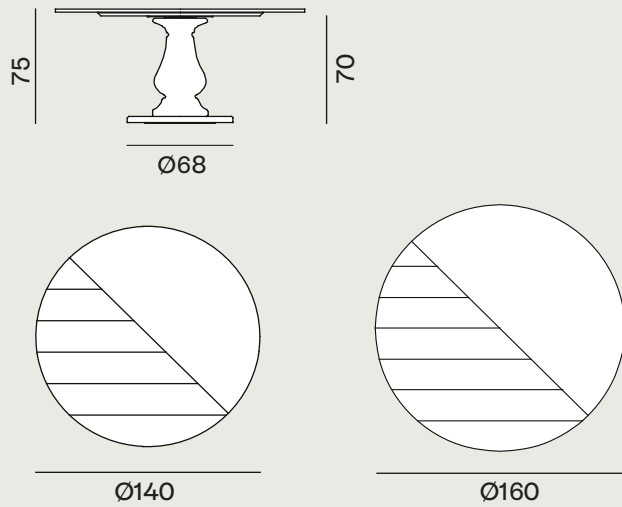

Legno doghe da 20 cm
/ 20 cm wooden slats

I. La bellezza della semplicità e il comfort prendono forma nella collezione Loll. Composta da divani e poltrone accoglienti e confortevoli, Loll racconta un'idea di comfort contemporaneo, reso speciale dalla cura dei dettagli, dalla qualità dei materiali e dall'unicità della lavorazione artigianale. Il profilo dei divani è sottolineato dalla caratteristica taglia / cuciture che, come un tratto leggero disegnato a mano libera, segue le geometrie essenziali e le linee morbide della collezione.

E. The beauty of simplicity and comfort take shape in the Loll collection. Composed of cosy and comfortable sofas and armchairs, Loll tells a story of contemporary comfort, made special by the attention to detail, the quality of the materials and the uniqueness of the craftsmanship. The profile of the sofas is underlined by the characteristic sew / cut which, like a light line drawn by hand, follows the essential geometries and soft lines of the collection.

F. La beauté de la simplicité et le confort prennent forme dans la collection Loll. Composée de canapés et de fauteuils accueillants et confortables, Loll raconte une idée de confort contemporain, qui est rendu spécial grâce à l'attention portée aux détails, à la qualité des matériaux et au caractère unique de l'artisanat. Le profil des canapés est rehaussé par des surpiqûres qui, tel un tracé léger et dessiné à la main, suivent les géométries essentielles et les lignes douces de la collection.

D. Schmucklose Schönheit und Komfort nehmen in der Kollektion Loll Form an. Die aus bequemen Sofas und Sesseln bestehende Kollektion Loll erzählt von modernem Komfort, der durch Detailgenauigkeit, Materialqualität und eine einzigartige handwerkliche Verarbeitung besonders wird. Das Profil der Sofas wird durch die charakteristische Overlocknaht unterstrichen, die wie freihändig flink der minimalistischen Geometrie und den weichen Linien der Kollektion folgen.

Loll Section

A →
Struttura / Structure /
Structure / Gestell

Struttura in legno massello preparata con poliuretano espanso a quote differenziate, localizzate, ad alta densità, al fine di migliorarne comfort, sofficià e durata. Rivestimento della struttura in fibra termolegata traspirante accoppiata con una maglina elastica bianca che ne conferisce maggior morbidezza. Piedi in polietilene ad alta resistenza, colore nero.

Structure in solid wood made of high resilience, variable-density polyurethane foam, in order to improve comfort, softness and durability. Structure covered with breathable, heat-bonded fiber laminated to white elastic jersey which gives it greater softness. Circular feet in high resistance black polyethylene.

Structure en bois massif associée à du polyuréthane expansé à densité différenciée haute résilience, garantissant confort, souplesse et longévité. Revêtement de la structure en fibre thermocollée respirante, doublée de jersey élastique blanc qui lui confère une plus grande douceur. Pieds circulaires en polyéthylène haute résistance, couleur noire.

Gestell aus Massivholz, Polsterung des Gestells der Sitzfläche aus PU-Schaum mit differenzierter, hoher Dichte, um Komfort, Weichheit und Langlebigkeit zu verbessern. Die Polsterung mit atmungsaktiver temperaturregulierter Faser sorgt zusammen mit dem elastischen weißen Stoff für eine große Weichheit. Runde Füße aus hochwiderstandsfähigem Polyethylen, schwarze Farbe.

B →
Imbottitura / Upholstery /
Garnissage / Füllung

I cuscini di seduta sono realizzati in piuma d'oca canalizzata (certificata Assopiuma) con inserto centrale in poliuretano espanso a quote differenziate ad alta resilienza e molle insacchettate.

Seat cushions in channeled goose down (Assopiuma Gold Label certified) with core insert in high-resilience, variable-density polyurethane foam and independent pocket springs.

Coussins d'assise en plume d'oie cloisonnée (certifiée Assopiuma, Label Or) avec insert central en polyuréthane expansé à densité différenciée haute résilience et ressorts ensachés.

Sitzkissen mit gesteppter Gänsedaunenfüllung mit Kammern und Innenstegen (zertifiziert Assopiuma, "Goldenes Etikett"), mit Kern aus hochwiderstandsfähigem PU-Schaum mit differenzierter Dichte und Federung.

C →
Cuscini / Cushions /
Coussins / Kissen

I cuscini di schienale sono realizzati in piuma d'oca canalizzata (certificata Assopiuma) e fibra di poliestere.

Backrest cushions in channeled goose down (Assopiuma Gold Label certified) and polyester fibers.

Coussins de dossier en plume d'oie cloisonnée (certifiée Assopiuma, Label Or) et fibres de polyester.

PU-Schaum mit differenzierter, hoher Dichte (zertifiziert Assopiuma, "Goldenes Etikett") und Polyesterfasern.

Sfoderabilità / Covers /
Déhoussage / Abziehbarkeit

I cuscini del sedile, dello schienale e la struttura sono completamente e facilmente sfoderabili a garanzia di una facile e frequente pulizia del rivestimento.

Structure, seat and backrest cushion covers are completely and easily removable in all versions, to guarantee easy and frequent cleaning of the covers.

Structure, coussins d'assise et de dossier entièrement et facilement déhoussables dans toutes les versions, permettant un lavage aisé et fréquent du tissu.

Gestell, Sitzkissen und Rückenissen sind in allen Versionen komplett abziehbar, was eine einfache und häufige Reinigung der Bezüge garantiert.

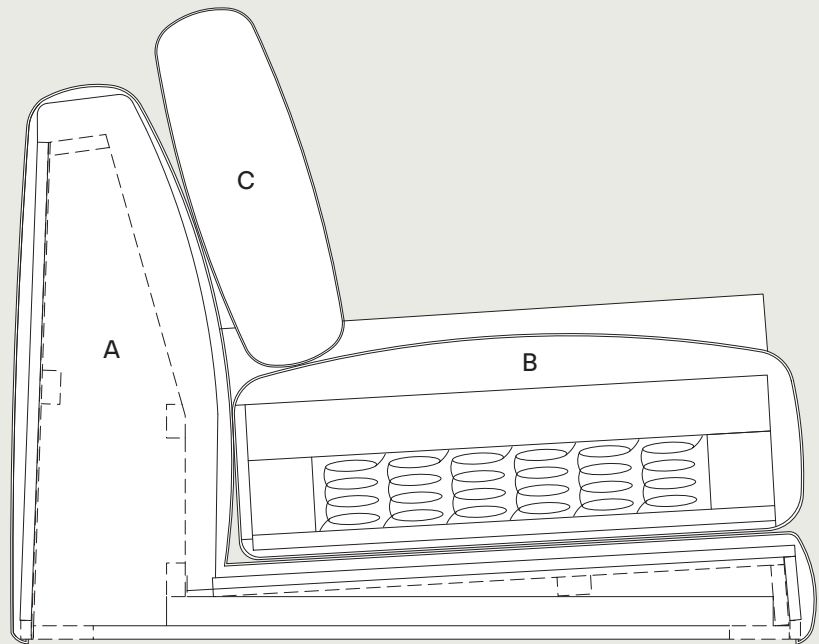

Loll 01 → P. 036-037

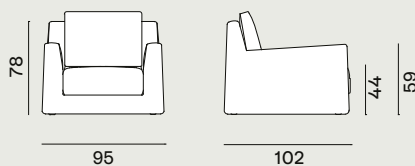

Loll 05 → P. 072, 083, 110

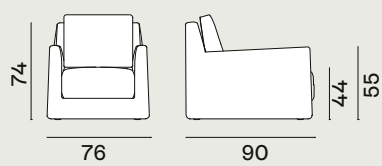

Loll 07 → P. 010-011, 085, 121, 151

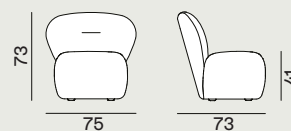

Loll 08 → P. 032, 055, 056, 058, 082, 120

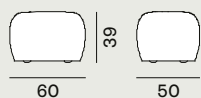

Loll 09 → P. 032-033, 050, 055, 120

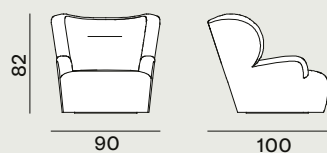

Loll 10

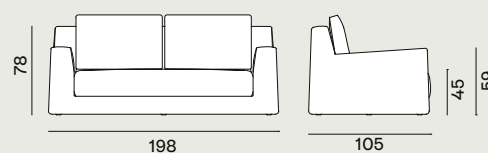

Loll 12 → P. 040, 106-107, 108

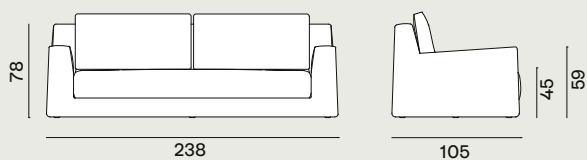

Loll 14 → P. 040-041

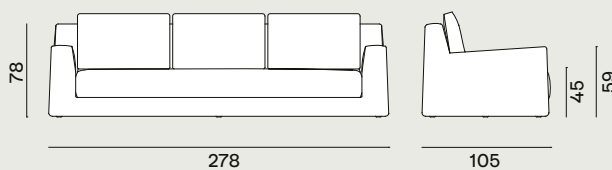

Loll 16 → P. 070-071

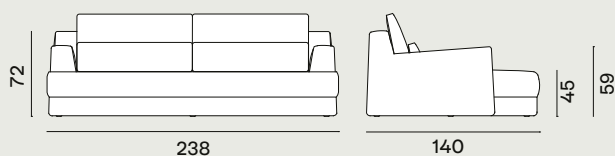

Loll 28 → P. 109, 161, 162

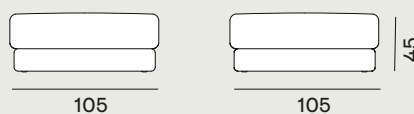

Loll 29 → P. 060, 061

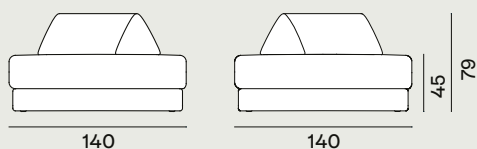

Loll 80 → P. 116-117, 142-143

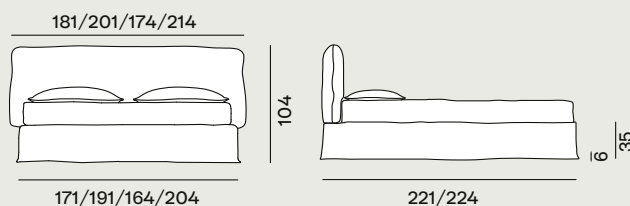

↳ Loll — Modular

Loll 20 L-R → P. 056-057, 074-075, 126-127, 129

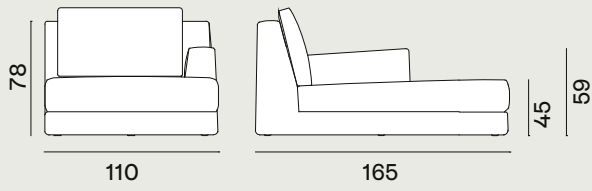

Loll 21 L-R → P. 056-057, 130-131, 160-161

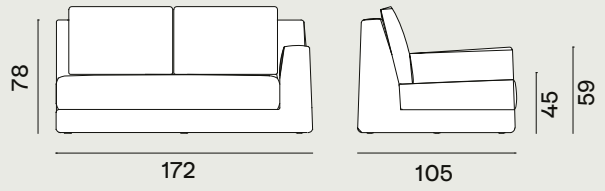

Loll 22 L-R → P. 012-013, 074-075, 101

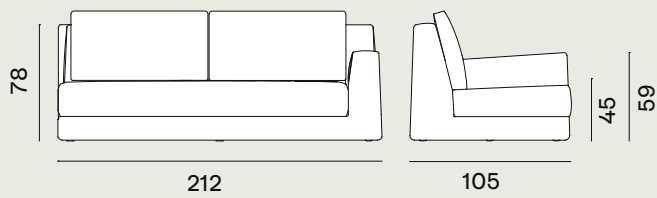

Loll 23 → P. 056-057, 130-131

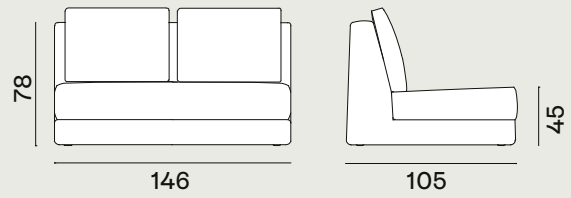

Loll 25 AN → P. 098-099, 101, 130-131

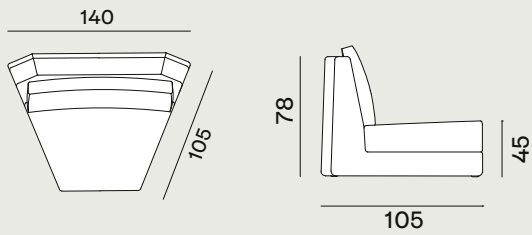

Loll 26 AN → P. 056-057, 130-131

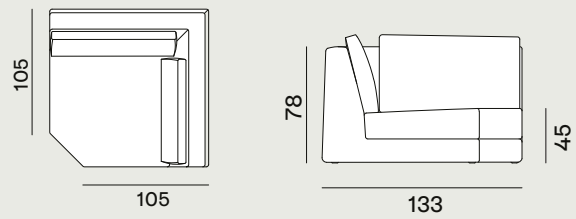

Loll 27 AN → P. 012-013

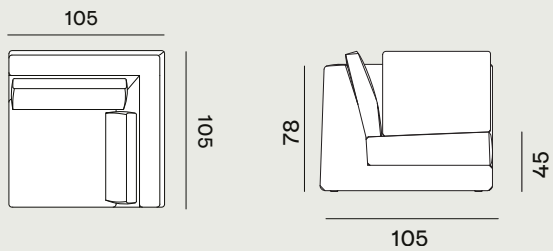

C. Loll PI

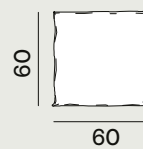

C. Loll XS

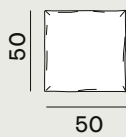

↳ Loll — Configurations

Loll Configuration 1 → P. 074-075

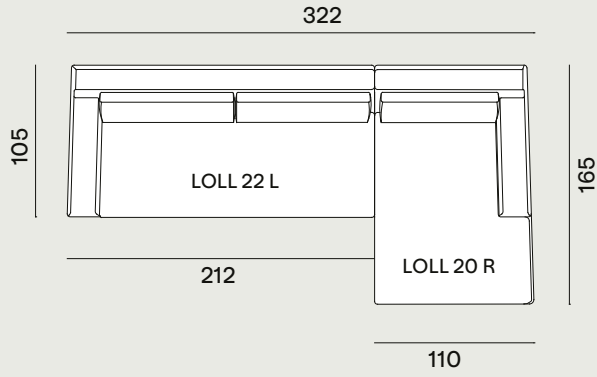

Loll Configuration 2

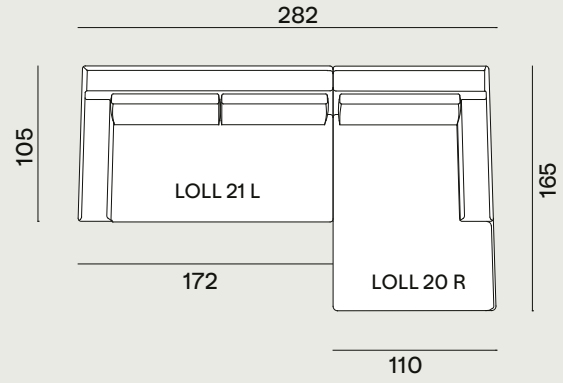

Loll Configuration 3 → P. 160-161

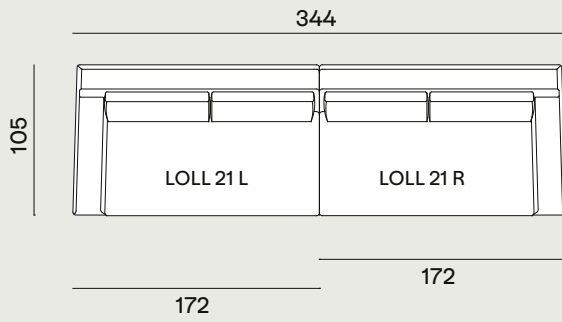

Loll Configuration 4

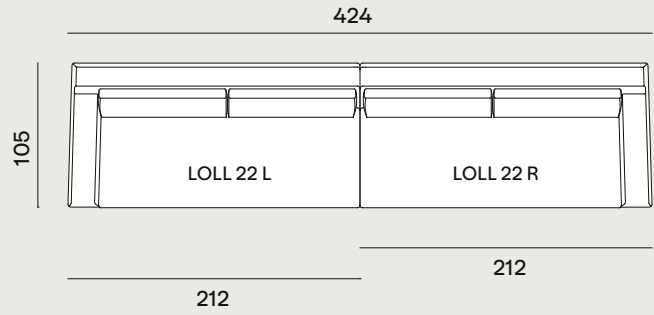

Loll Configuration 5

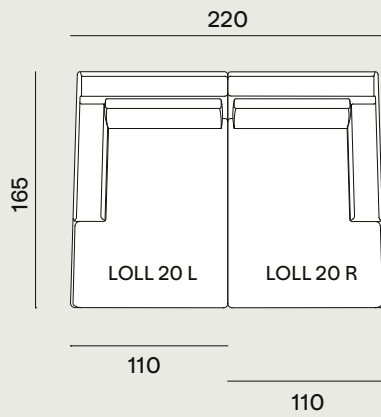

Loll Configuration 6

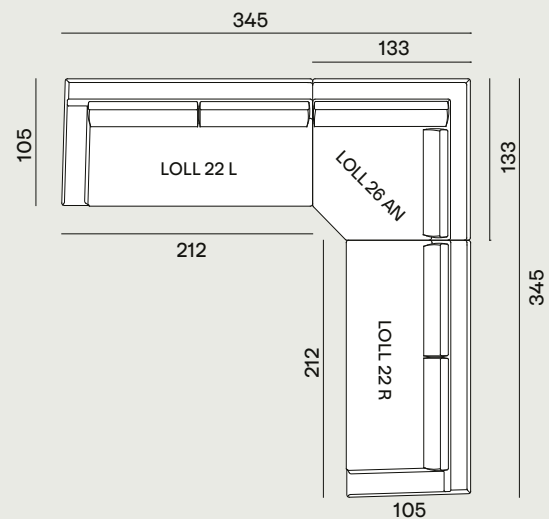

↳ Loll — Configurations

Loll Configuration 7

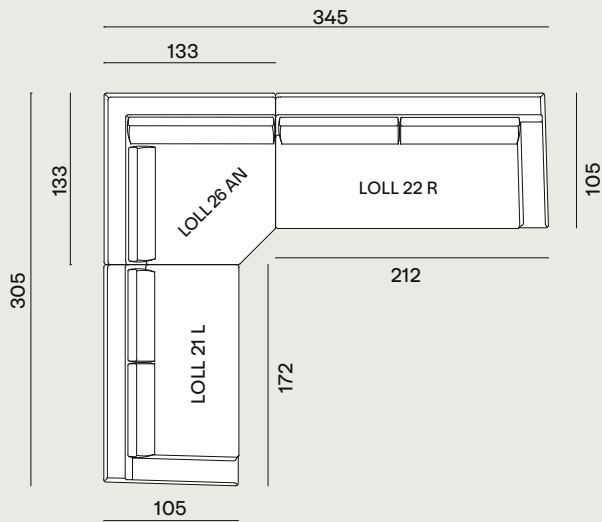

Loll Configuration 8 → P. 012-013

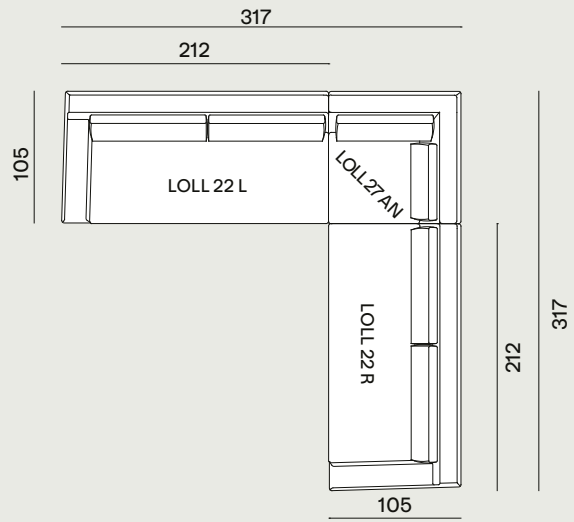

Loll Configuration 9

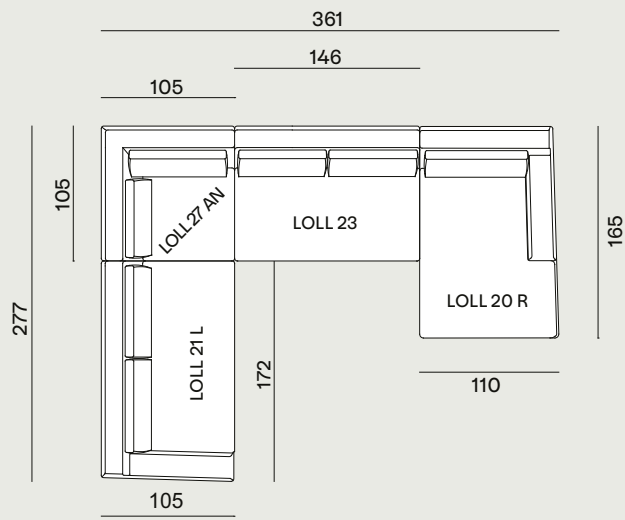

Loll Configuration 9/Bis → P. 056-057

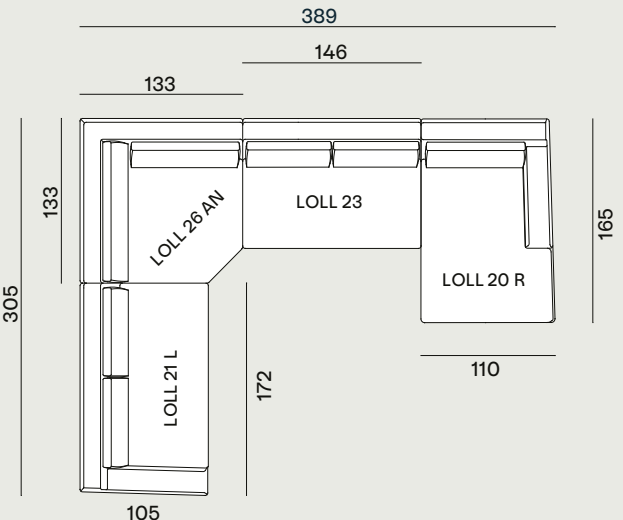

Loll Configuration 10 → P. 098-099, 101

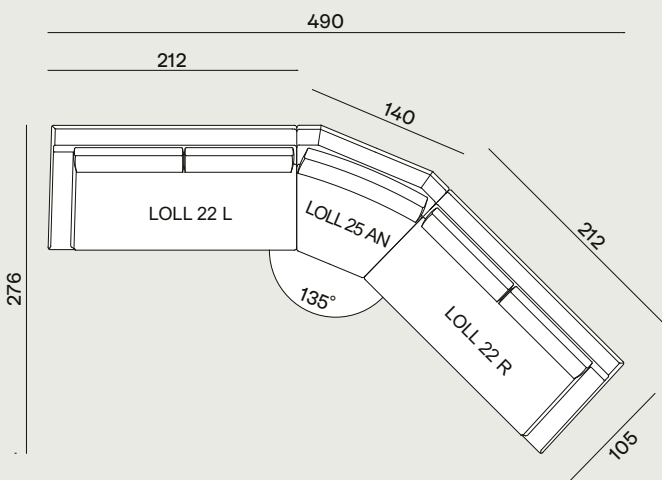

Loll Configuration 11 → P. 130-131

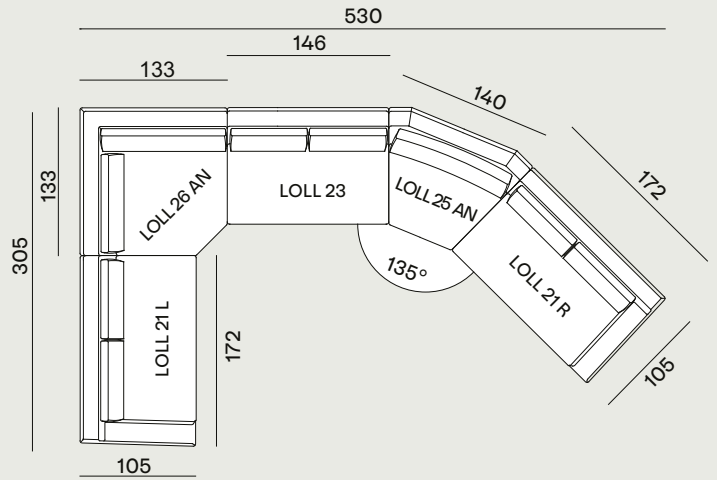

I. Forme semplici e raffinate che si esaltano negli inediti abbinamenti di materiali caratterizzano Next, collezione di arredi dedicati al living e alla zona dining. Dai tavoli scultorei con base di cemento in finitura craclè, ai tavoli e tavolini con basi in fusione di alluminio, ogni elemento assume, a seconda degli abbinamenti di materiali e finiture, un aspetto sempre diverso, classico, essenziale o pop.

E. Simple and refined shapes that are enhanced by the unprecedented combinations of materials characterise Next, a collection of furnishings dedicated to the living and dining area. From the sculptural tables with a concrete base in a crackle finish, to the tables and coffee tables with cast aluminium bases, each element assumes, depending on the combinations of materials and finishes, an always different, classic, essential or pop appearance.

F. Des formes simples et raffinées rehaussées par des combinaisons de matériaux innovantes définissent Next, une collection de meubles dédiée au salon et à la salle à manger. Des tables sculpturales avec un piétement en béton dans une finition craquelée, aux tables et tables basses présentant des bases en fonte d'aluminium, chaque élément prend, selon les combinaisons de matériaux et de finitions, un aspect toujours différent, classique, essentiel ou pop.

D. Einfache und raffinierte Formen in nie dagewesener Zusammenstellung von Materialien kennzeichnen Next, die Einrichtungskollektion für den Wohn- und Essbereich. Von den Skulpturtischen mit Betonfuß mit Crackle-Finish zu den Tischen und Beistelltischen mit Füßen aus Aluminiumguss nimmt jedes Element je nach Materialzusammenstellung und Finish ein immer anderes Aussehen an - klassisch, minimalistisch oder schrill.

Struttura / Structure



Alluminio
Aluminium

Next 141 → P. 012, 098

Next 142 → P. 013, 078, 098

Next 144 → P. 013, 130

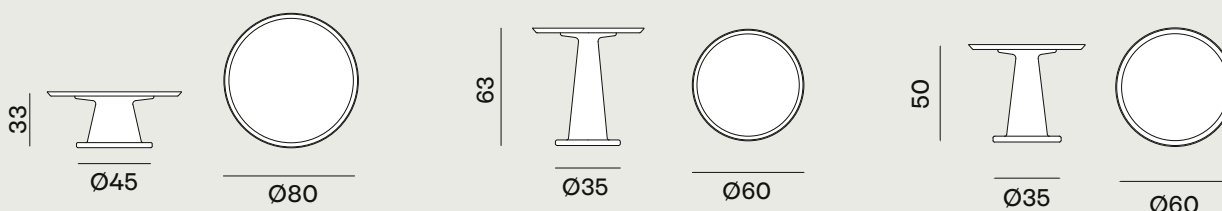

Next 147 → P. 037, 130-131, 133

Next 148 → P. 037, 078-079, 085, 130-131, 133



↳ Next — Tables & Chairs

Piano Tavolo / Table Top

Base Tavolo / Table Base



Legno
Wood



Marmo Bianco
White Marble



Fusione Alluminio
Cast Aluminium

Finiture Legno / Wood Finishes
Piano e gambe sedia / Table Top
e chair legs



Tortora
Dove-Grey



Oceano
Ocean



Noce
Walnut



Bianco
White



Grigio
Grey



Nero
Black

Next 25 → P. 022-023, 086-087, 088

* Solo finiture legno / Only wood finishes

Next 132

Next 136 → P. 022-023, 066

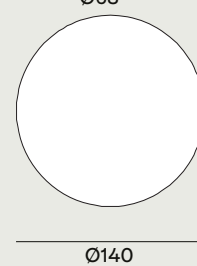
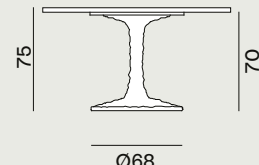
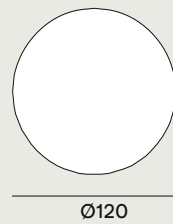
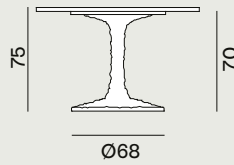
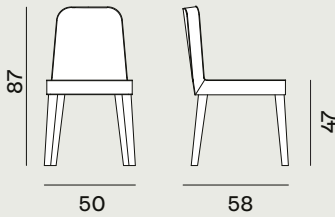

Next 137 → P. 044-045, 166-167

Next 138

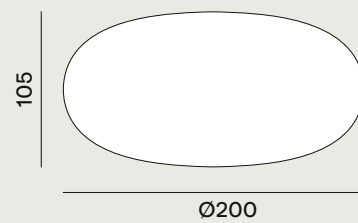
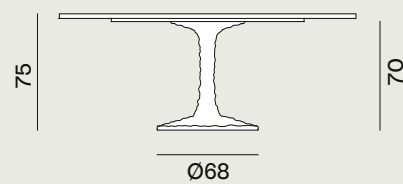
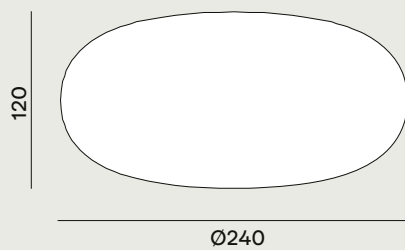
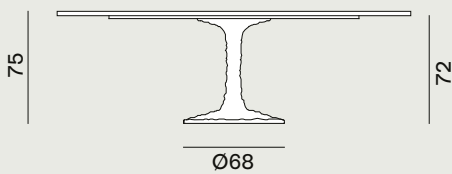

Piano Tavolo / Table Top

Base Tavolo / Table Base



Marmo Bianco
White Marble



Cemento Crackle
Crackle Concrete

Next 232

Next 236 → [P. 112-113](#)

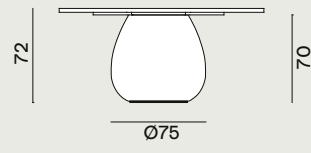
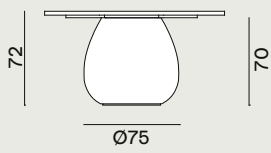

Tappeti / Carpets

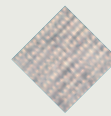

Argento
Silver

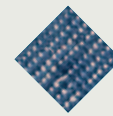

Blu
Blue

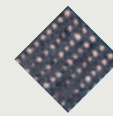

Ardesia
Slate

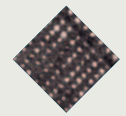

Marrone
Brown

Next 998 → [P. 096](#)

Next 999 → [P. 156-157, 168-169](#)

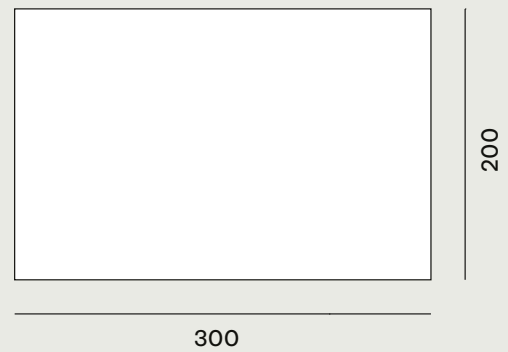
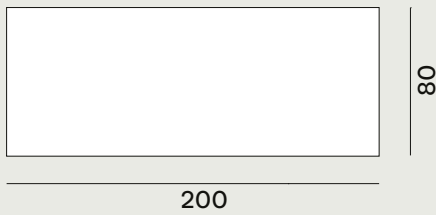

↳ Nuvola

I. Nuvola è una collezione di imbottiti, composta da poltrone e divani, che si contraddistingue per le sue forme soffici e attraenti. Un imbottito oversize dall'aria informale, completamente sfoderabile, che cambia look a seconda del rivestimento scelto. Divani e poltrone hanno l'imbottitura in poliuretano espanso a quote differenziate rivestita con trapuntino imbottito con piuma d'oca e fiocco di fibra di poliestere per un confort ancora più accentuato.

E. Nuvola is a collection of upholstered furniture, consisting of armchairs and sofas, characterised by soft and attractive shapes. An oversized upholstery with an informal feel, completely removable, which changes its look depending on the chosen upholstery. Sofas and armchairs are padded with multi-density polyurethane foam covered with quilt padded with goose down and polyester fibre staple for an even more accentuated comfort.

F. Nuvola est une collection de meubles d'assise rembourrés, composée de fauteuils et de canapés qui se distinguent par leurs formes douces et séduisantes. Une assise rembourrée et oversize au style informel, dont la housse est entièrement amovible et change d'aspect en fonction du revêtement choisi. Les canapés et les fauteuils présentent un rembourrage en mousse de polyuréthane expansé de différentes densités et recouvert d'un capitonnage rembourré avec du duvet d'oie et des flocons de fibres de polyester pour un confort encore plus accentué.

D. Nuvola ist eine Kollektion von Polstermöbeln, bestehend aus Sofas und Sesseln, die sich durch die weichen und einladenden Formen auszeichnen. Die komplett abziehbaren Oversize-Polstermöbel mit lässigem Charakter ändern je nach Bezug ihr Aussehen. Die Sofas und Sessel sind mit PU-Schaumstoff in unterschiedlicher Dichte gepolstert und für noch mehr Komfort mit einem Steppbezug versehen, der mit Daunen und Flocken aus Polyesterfasern befüllt ist.

Nuvola Section

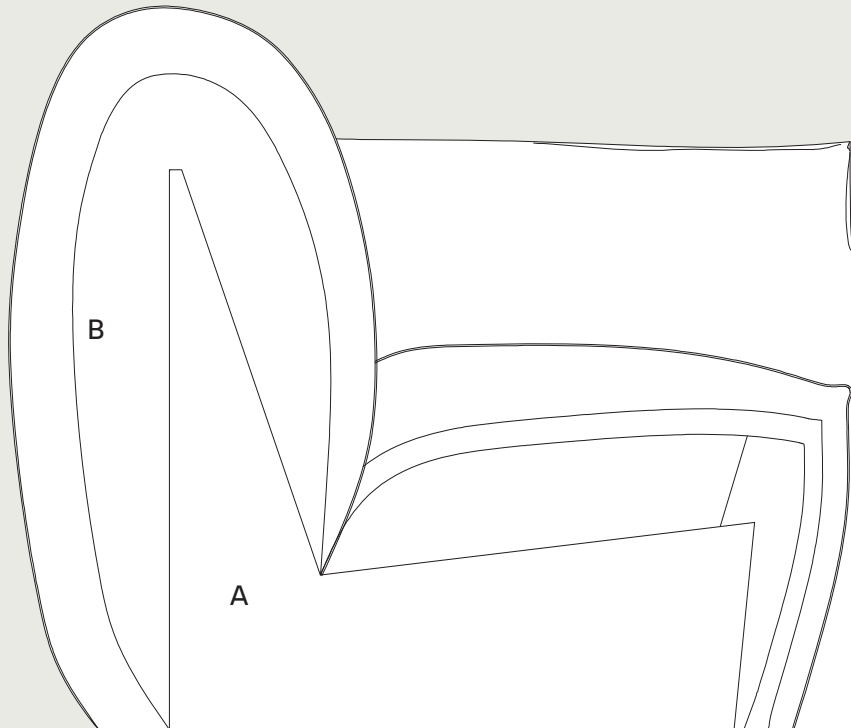

A →
*Struttura / Structure /
Structure / Gestell*

La struttura interna della seduta e dello schienale è realizzata in multistrati e masselli di abete.

The inside structure, of both the back and seat, is in solid and multilayered fir wood.

La structure interne de l'assise et du dossier est réalisée en multiplis et en bois massif de sapin.

Das Sitz- und Rückengestell besteht aus Multischicht- und Massivtannenholz.

B →
*Imbottitura / Upholstery /
Garnissage / Füllung*

L'imbottitura in poliuretano espanso è rivestita con trapuntino imbottito con piuma d'oca e fiocco di fibra di poliestere.

The upholstery is made with polyurethane foam covered by a goose down and polyester fibre quilting.

Rembourrage en mousse polyuréthane avec couche ultérieure en duvet et polyester.

Polsterung aus Polyurethanschaum, Weißpolsterbezug gefüllt mit Daunen und Polyesterflockchen.

*Sfoderabilità / Covers /
Déhoussage / Abziehbarkeit*

Struttura completamente e facilmente sfoderabile a garanzia di una facile e frequente pulizia del rivestimento.

Cover completely and easily removable to guarantee easy and frequent cleaning.

Elements entièrement et facilement déhoussables permettant un lavage aisé et fréquent du tissu.

Komplett abziehbare Elemente, was eine einfache und häufige Reinigung der Bezüge garantiert.

↳ Nuvola

Nuvola 05 → [P. 043, 096, 142](#)

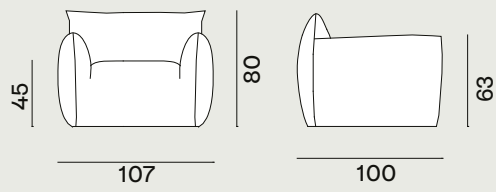

Nuvola 09 → [P. 156-157](#)

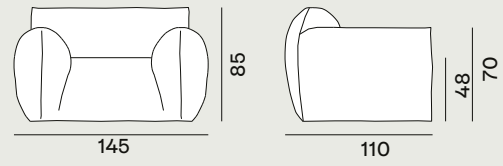

Nuvola 10

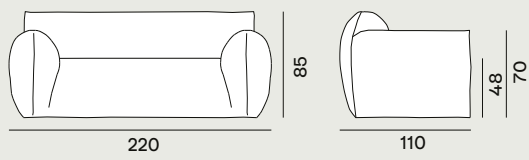

Nuvola 12 → [P. 090-091, 154-155](#)

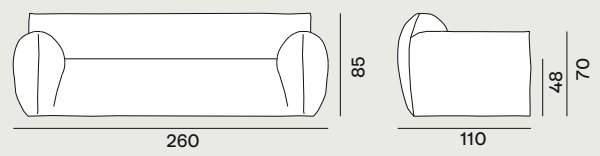

↳ Eco Rugs

I. Vibrazioni, suoni e colori, elementi carichi di suggestioni che contraddistinguono l'ambiente naturale a cui si ispira la collezione di tappeti ECO. La sintesi tra tradizione e innovazione emerge anche nella scelta dei materiali utilizzati, iuta e propilene, entrambi idonei per l'utilizzo in esterno e resistenti all'acqua. Una collezione di tappeti freschi, leggeri e trasportabili che definiscono lo spazio outdoor vibrando con la natura che li circonda. Adatto sia per indoor sia per outdoor.

E. Vibrations, sounds and colours, elements full of suggestions that distinguish the natural environment that inspires the ECO carpet collection. The synthesis of tradition and innovation is also palpable in the choice of materials: jute and propylene are both suitable for outdoor use and are water resistant. A collection of fresh, lightweight and transportable carpets that define outdoor areas, vibrating with the surrounding nature. Suitable for both indoor and outdoor.

F. Vibrations, sons et couleurs, des éléments qui regorgent de suggestions et qui distinguent l'environnement naturel qui inspire la collection de tapis ECO. La synthèse entre tradition et innovation émerge également dans le choix des matériaux utilisés, jute et propylène, tous deux adaptés à un usage extérieur et résistants à l'eau. Une collection de tapis frais, légers et transportables qui définissent l'espace extérieur en vibrant avec la nature qui les entoure. Convient aussi bien à l'intérieur qu'à l'extérieur.

D. Schwingungen, Klänge und Farben, Elemente voller Eindrücke, die das natürliche Ambiente kennzeichnen, von dem die Kollektion an Teppichen ECO Inspiration bezieht. Die Synthese zwischen Tradition und Innovation zeigt sich auch in der Materialauswahl, Jute und Polypropylen, beide wasserfest und damit geeignet für Outdoor-Anwendungen. Eine Kollektion an frischen, leichten und transportierbaren Teppichen, die den Outdoor-Bereich definieren und im Einklang mit der umgebenden Natur stehen. Geeignet für Indoor- und Outdoor-Bereiche.

Eco Rug Green

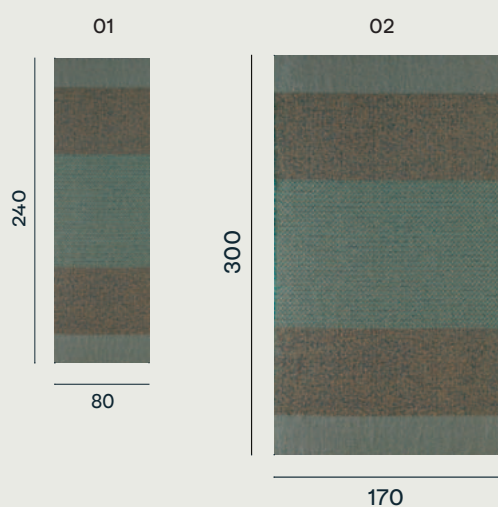

Eco Rug Natural → P. 025, 046, 047-048

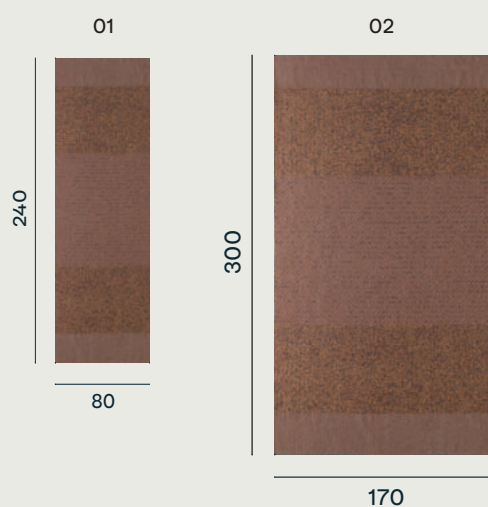

Eco Rug White

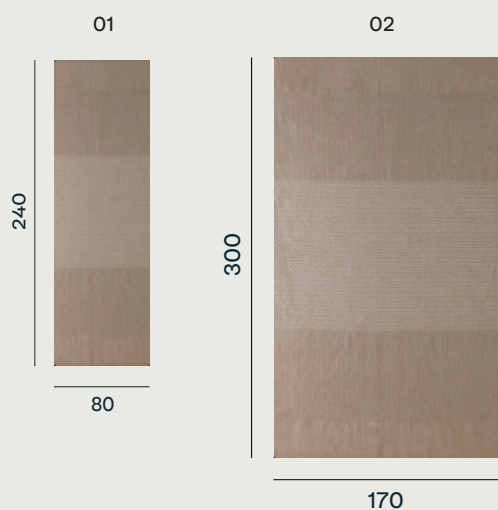

↳ Guna Rugs

I. I tappeti Guna nascono da una lavorazione innovativa che parte da un concetto di trama e ordito dal sapore artigianale, trasportato nella perfezione e serialità dei telai industriali. Un sottilissimo filato in polipropilene, in due colori a contrasto, viene intrecciato da un telaio da maglieria di ultima generazione, e trasformato in un tappeto innovativo disponibile in due versioni, una con una texture rigata e una più decorativa, double face. Adatto sia per indoor sia per outdoor.

E. Guna carpets are born from an innovative process that starts from a concept of weft and warp with a handcrafted flavour, transported into the perfection and seriality of industrial looms. A very thin polypropylene yarn, in two contrasting colours, is woven by a next generation knitting loom and transformed into an innovative carpet available in two versions, one with a striped texture and a more decorative, double-faced one. Suitable for both indoor and outdoor..

F. Les tapis Guna naissent d'un processus innovant qui part d'un concept de fil de trame et de chaîne de type artisanal, transporté dans la perfection et la sérialité des métiers à tisser industriels. Un fil de polypropylène ultra fin et de deux couleurs contrastées est tissé par un métier à tricoter de dernière génération, et transformé en un tapis innovant disponible en deux versions : une arborant une texture rayée et l'autre plus décorative et double face. Convient aussi bien à l'intérieur qu'à l'extérieur.

D. Die Teppiche Guna entstehen durch eine innovative Verarbeitung ausgehend von einem handwerklichen Kett-Schuss-Konzept mit der Perfektion der serienmäßigen industriellen Fertigung. Ein hauchdünnes Garn aus Polypropylen in zwei kontrastierenden Farben wird von einem Webstuhl der neuesten Generation verflochten und in einen innovativen Teppich in zwei Variationen verwandelt, einer Version mit gestreifter Textur und einer dekorativen Version zum Wenden. Geeignet für Indoor- und Outdoor-Bereiche.

Guna Rug Blue → P. 134-135

Guna Rug Natural → P. 055

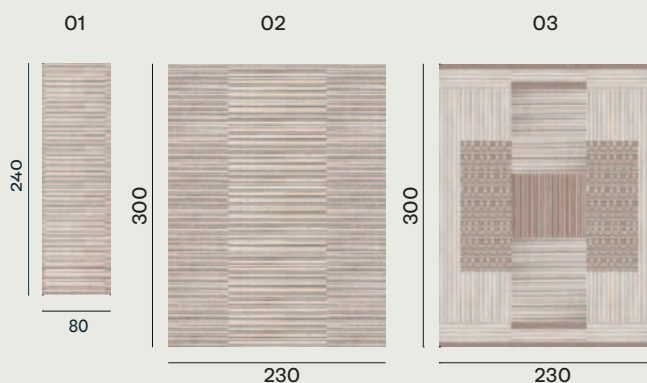
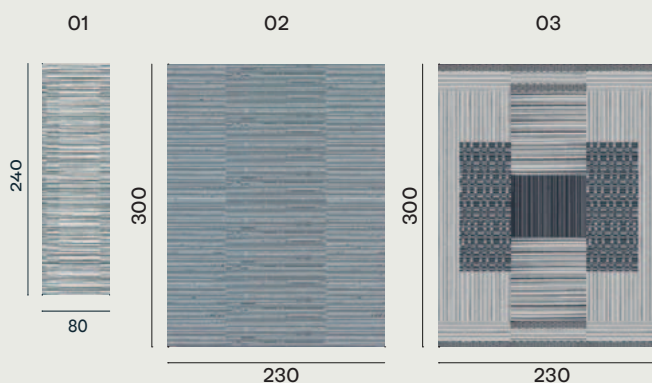

Guna Rug Red → P. 010-011

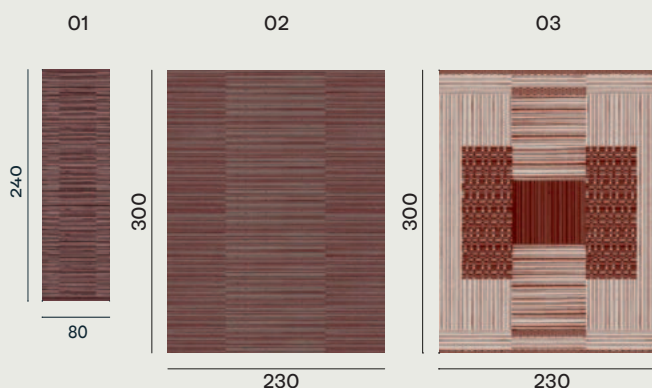

↳ Sweet

I. Un intreccio armonioso e curve sinuose contraddistinguono la collezione Sweet. Saperi artigianali di antica tradizione si combinano a materiali contemporanei dando vita a sedute, lampade e specchi dal look accattivante che conferiscono ad ogni ambiente indoor grande forza espressiva.

E. A harmonious intertwining and sinuous curves distinguish the Sweet collection. Profound knowledge of ancient tradition is combined with contemporary materials, giving life to seats, lamps and mirrors with a captivating look that give every indoor environment great expressive force.

F. La collection Sweet se distingue par un tissage harmonieux et des courbes sinueuses. Le savoir-faire artisanal de la tradition ancienne est combiné à des matériaux contemporains, donnant ainsi vie à des sièges, des lampes et des miroirs au style captivant et qui confèrent à chaque espace intérieur une grande force expressive.

D. Harmonische Verflechtungen und üppige Formen kennzeichnen die Kollektion Sweet. Handwerk nach antiker Tradition verbindet sich mit modernen Materialien und haucht Sitzen, Lampen und Spiegeln mit ansprechendem Aussehen Leben ein, die jedem Innenbereich große Ausdrucksstärke verleihen.

Intreccio / Weaving



Bianco
White

Nero
Black

Sweet 27 → P. 148, 149, 175

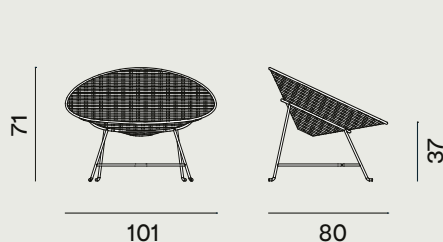

Sweet 91 → P. 120, 166-167

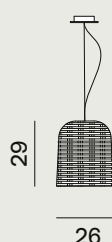

Sweet 95 → P. 113

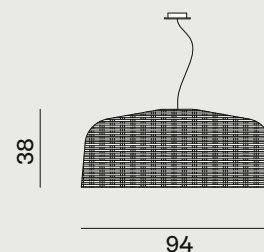

Sweet 96 → P. 066

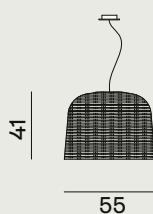

Sweet 97 → P. 126-127, 130-131

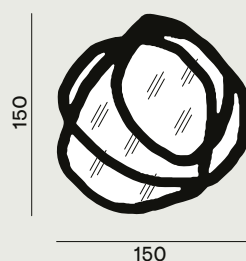

Sweet 98 → P. 011, 025, 047, 065

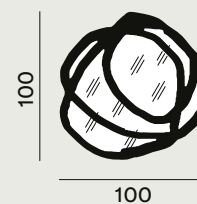

Abacus by Categories

Armchairs

→

Gray 01 → P. 124



Gray 06 → P. 023, 029, 041



Gray 07 → P. 013-014, 090



Gray 08 → P. 021



Gray 09 → P. 136-137

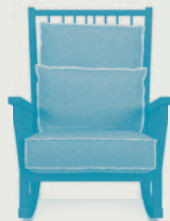

Gray 29 → P. 035, 169, 171



Loll 01 → P. 036-037



Loll 05 → P. 072, 083, 110



Loll 07 → P. 010-011, 085, 121, 151



Loll 09 → P. 032-033, 050, 055, 120



Nuvola 05 → P. 043, 096, 142



Nuvola 09 → P. 156-157



Sweet 27 → P. 148-149, 175



Allu 223 → P. 044, 077



Allu 224 → P. 045



Brick 221 → P. 166-167



Chairs

→

Brick 223 → P. 165



Ghost 23 → P. 046-047, 102-103, 138



Gray 21 → P. 066, 113



Gray 22 → P. 114-115, 134-135



Gray 23 → P. 039, 062, 087, 112



Gray 24 → P. 016, 138-139



Gray 26 → P. 016, 018, 065



Next 25 → P. 022-023, 086-087, 088



Up 23 → P. 146



Gray 03 → P. 082-083, 124-125

Sofas



Gray 04 L-R → P. 026-027, 173



Gray 05 → P. 010-011, 078



Loll 10



Loll 12 → P. 040, 106-107, 108



Loll 14 → P. 040-041



Loll 16 → P. 070-071



Loll 20 L-R → P. 126-127, 129



Nuvola 12 → P. 090-091, 154-155

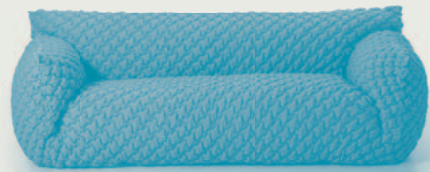

Gray 32 → P. 077

Tables & Desks



Gray 33 → P. 016-017, 086-087, 088, 102-103, 138-139, 140

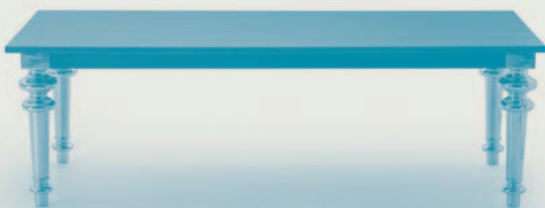

Gray 38 → P. 046-047, 114-115, 135



Gray 50 → P. 065



Gray 51 → P. 062, 064



Gray 61 → P. 025, 015, 097



Next 136 → P. 022-023, 066



Next 137 → P. 044-045, 166-167



Next 236 → P. 112-113



Brass 43 → P. 142-143

Brass 44 → P. 071, 146, 155

Brass 45 → P. 070, 155

Coffee Tables



Brass 46 → P. 165

Brick 241 → P. 026-027, 057, 060, 160-161

Brick 242 → P. 026-027, 057, 160-161

Brick 244 → P. 026-027



Brick 247 → P. 012-013, 160-161



Brick 248 → P. 012-013, 160-161



Gray 39 → P. 039



Gray 41 → P. 029



Gray 42 → P. 040-041, 107, 124-125, 156



Gray 44 → P. 124-125, 156



Gray 45 → P. 118, 168



Gray 46 → P. 099, 154-155



Gray 49 → P. 040-041, 070-071



LC 47 → P. 116



Next 141 → P. 012, 098



Next 142 → P. 013, 078, 098



Next 144 → P. 013, 130



Next 147 → P. 037, 130-131, 133



Next 148 → P. 037, 078-079, 085, 130-131, 133



Beds



Double → P. 168-169



Loll 80 → P. 116-117, 142-143

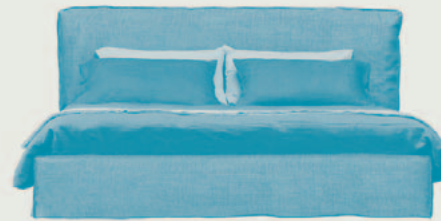

Complements



Bolla 10



Bolla 12 → P. 057



Bolla 13 → P. 043



Bolla 15 → P. 043, 075



Brick XS, S, M, L → P. 034-035, 082-083, 096, 106



Corallo → P. 094



Gray 15 → P. 142-143, 168-169, 172



Inout 44 → P. 106, 108



Inout 45

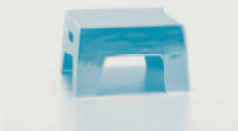

Inout 46 IN → P. 151



LC 97 → P. 170



LC 198 → P. 117-119



Log S, M, L → P. 010-011, 033, 050, 175



News 108 → P. 055, 061



Sweet 97 → P. 126-127, 130-131



Sweet 98 → P. 011, 025, 047, 065



Brick 18 → P. 026-027, 071, 091

Brick 19 → P. 026-027, 071, 091

Loll 08 → P. 032, 055-056, 058, 082, 120

Poufs

→



Loll 28 → P. 109, 161, 162

Loll 29 → P. 060-061



Bell 95 → P. 114-115

Bolla S, M, L, XL → P. 056-057, 059, 130-131

Brass 95 → P. 061, 102-103, 155

Lightings

→



Brass 96 → P. 016-017, 135, 151, 155

LC 91 → P. 168

Silver 95 → P. 086-087, 098, 101

Silver 96 → P. 074, 098, 101

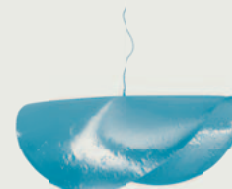
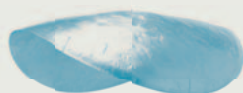

Spin 95 → P. 142-143



Spin 96 → P. 146



Spin S, M, L → P. 012-013, 032, 037



Sweet 91 → P. 120, 166-167



Sweet 95 → P. 113



Sweet 96 → P. 066



Eco 01



Eco 02 → P. 025, 046-047, 048



Guna 01 → P. 010-011



Rugs
→

Guna 02



Guna 03 → P. 010-011, 055, 134, 135

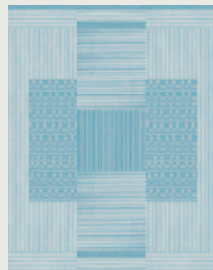

Next 998 → P. 096



Next 999 → P. 156-157, 168-169

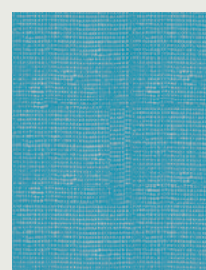

Credits:

Concept + Design:
Choice–Studio

Product design:
Paola Navone
Domenico Diego
OTTO

Photo:
Max Rommel

Styling:
Ilaria Baccocchi
Studio

Separation:
Luce Srl

Printed in Italy:
Grafiche Antiga
September 2021

Thanks to:

Lighting
Astep
Foscarini
Luceplan
Martinelli Luce
Nemo Lighting
Oluce
Pallucco
Penta Light
Tato Italia

Carpets:
Alberto Levi Gallery
Via San Maurilio 24
20123 Milano
+ 39 02 890 115 53
Albertolevi.com

Amini Carpets
Cc-Tapis
Golran
I-And-I
Illullian
Karpeta
Kasthall
Mohebban

Objects
Mmairo – Marble &
Design
Salvatori
Limonta Society

GERVASONI®

1882

Gervasoni spa è dotata di un Sistema di Qualità Certificato UNI EN ISO 9001, di un Sistema per la gestione della Sicurezza e della Salute dei lavoratori Certificato ISO 45001 e di un Sistema di Gestione Ambientale Certificato UNI EN ISO 14001 / Gervasoni spa is certified to: UNI EN ISO 9001 Company Quality System Certification, ISO 45001 Certification for Health and Safety Management Systems and UNI EN ISO 14001 Environmental Management System Certification.



IDB

Gervasoni fa parte del gruppo Italian Design Brands /
Gervasoni is part of Italian Design Brands Group



CATGRAY21

© Copyright 2021 Gervasoni S.p.A.
Tutti i diritti riservati



